

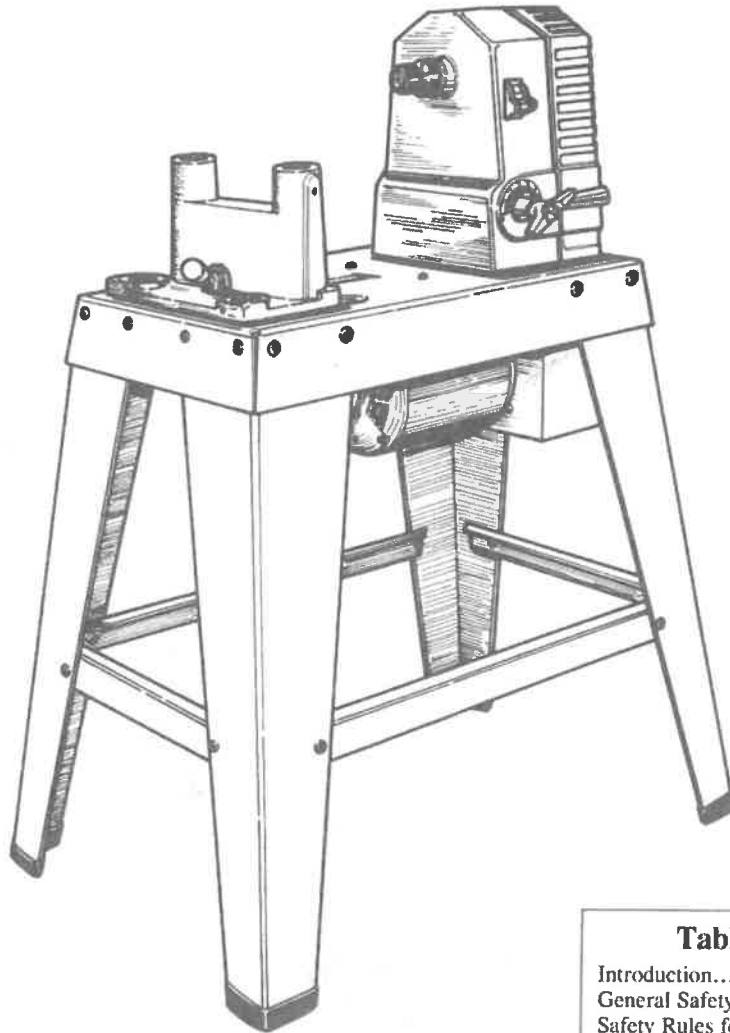

Power Station

Owners Manual



WARNING

Read the SAFETY section and complete the *Assembly* procedures before operating the Power Station.

Table of Contents

Introduction.....	1
General Safety Rules for Power Tools	5
Safety Rules for Power Station.....	7
Terms to Know	8
Parts List.....	10
Exploded View.....	11
Assembly.....	12
Bandsaw.....	16
Jointer	20
Scroll Saw	23
Strip Sander	27
Belt Sander	30
Jigsaw	33
Disc Sander.....	36
Drum Sander	38
Flutter Sander	39
Flexible Shaft	40
Maintenance Schedule	41
Troubleshooting Guide	41

Page Intentionally Blank

SHOPSMITH POWER STATION

INTRODUCTION

Congratulations on your purchase of the Shopsmith Power Station. Within five square feet of floor space, you can now start your own workshop— or give yourself the flexibility and convenience you need to handle projects in your present workshop. The Shopsmith Power Station is designed to run the following **Major Accessories**:

- Shopsmith Bandsaw
- Shopsmith Jointer
- Shopsmith Scroll Saw
- Shopsmith Strip Sander
- Shopsmith Belt Sander
- Shopsmith Jigsaw

NOTE

Alignment of a Major Accessory may differ between the Shopsmith MARK V and the Power Station. If you intend to use a Major Accessory listed above on BOTH the MARK V and the Power Station, the Major Accessory should be accurately aligned on the Power Station first. Then when you use a Major Accessory on the MARK V, slight variances in horizontal alignment can be overcome by adjusting the setscrew in the MARK V headrest (see your MARK V Owners Manual). Vertical alignment between your Major Accessory (already aligned with the Power Station) and the MARK V should not be required.

You can also use the Shopsmith Power Station with **other Accessories** available through Shopsmith, including:

- Disc Sander
- Drum Sander
- Flutter Sheet Sander
- Flexible Shaft (and various bits fitting into its chuck)

This Owners Manual tells you how to install and use each of the above Accessories with the Power Station. For details on operating a specific Accessory, you should consult the Accessory's owners manual. If you are missing the Accessory's owners manual, call or write Shopsmith at the phone numbers and address listed on the back cover of this manual.

WARNING

Do NOT attempt to operate any equipment unless you carefully read and understand ALL the instructions—especially the "Safety" sections— in BOTH this manual AND the manual which came with the accessory you wish to use with the Shopsmith Power Station. See this manual's back cover for service information inquiries.

SAFETY

The Shopsmith Power Station has many built-in features. But the effectiveness of these features depends on you. Power tool safety requires good common sense. Misuse of the Power Station or an Accessory you use with it can cause serious injury.

To protect yourself from injury:

- **READ, UNDERSTAND AND FOLLOW ALL** the information and instructions in this Owners Manual.
- Also, **READ, UNDERSTAND AND FOLLOW ALL** the information and instructions in the Owners Manual that comes with each Accessory you use with the Power Station.

Throughout this manual, we list **WARNINGS, CAUTIONS, and NOTES**. We advise that when you come to one of these listings, make sure you read and understand it fully. Their meanings are:

WARNING

A WARNING is given when failure to follow the directions is likely to result in injury, loss of limb, or life.

CAUTION

A CAUTION is given when failure to follow the directions is likely to result in damage to the equipment.

NOTE

A NOTE is used to highlight an important procedure, practice or condition.

Eye Protection

- Always wear eye protection when you use power tools. Use goggles, safety glasses or a face shield to protect your eyes.
- Goggles completely surround and protect your eyes. Many goggles will also fit over regular glasses. Be sure your goggles fit closely, but comfortably.

-
- Safety glasses don't fog as easily as goggles and can be worn all the time. Regular glasses normally have only impact resistant lenses and nose shields. They are not safety glasses.
 - A face shield protects your entire face, not just your eyes.

Hearing Protection

- Prolonged exposure to high intensity noise from high speed power tools can damage your hearing.
- Hearing protectors screen out noise levels that can damage your ears, and are always recommended while using the Power Station with all Accessories.

Guarding

Most shop accidents happen to woodworkers who fail to follow instructions, or fail to use guards and safety devices. Although proper use of guards and safety devices often requires additional setup, the protection of you and your family should be your primary concern, and is well worth the effort.

Dress

- Loose hair and clothing which could be entangled in rotating cutters are very hazardous.
- Tuck long hair under a hat or tie it up. Do not wear ties, gloves, loose clothing, rings or other jewelry. Roll sleeves up above your elbows. Be aware of rotating parts and stay clear of them.

Electrical Requirements

Grounding— The circuit you use should be properly grounded to protect you from electrical shock. The plug has three prongs. The receptacle should have three corresponding holes. Do not modify the plug. If it will not fit the outlet, have the proper outlet installed. If you have a two-hole receptacle, use a temporary adapter. The grounding lug or wire on the adapter **MUST** be connected to a permanent ground such as a grounded outlet box. The temporary adapter should be used only until a properly grounded outlet can be installed. (Adapters are not allowed in Canada.)

Extension Cord— If you use an extension cord, be sure it's a three-conductor cord with a grounding plug and receptacle. The wire gauge must be large enough to prevent loss of power and overheating.

WIRE GAUGE CHART

Cord Length	Minimum Wire Size
25 ft.	14 AWG
50 ft.	12 AWG
100 ft.	10 AWG

Do not use an extension cord with loose wires or damaged insulation. Also, do not let the connection between the power cord and extension cord lie on a damp or wet surface.

Dust Collection

- Whenever you work with wood we highly recommend that you connect the hose of a Shopsmith DC3300 Dust Collector or another dust collection system to the chute on your Accessory, if it has one.

WARNING

DON'T operate any dust collection system nor connect hoses if you are sharpening or grinding metal.

Sawdust and Chips

Sawdust and chips can be a fire hazard and breathing sawdust can be a health hazard. The sawdust from some woods is toxic. To help protect yourself from sawdust:

- Attach the Accessory mounted on the Power Station to a dust collection system.
- Wear a close-fitting dust mask. Clean or replace the filters in the mask regularly. Also, open a window or use a fan to ventilate your shop.

GENERAL SAFETY RULES FOR POWER TOOLS

- **Know your power tool. Read the Owners Manual. Learn its applications and limitations as well as the specific potential hazards peculiar to this tool.**
- **Ground all tools (unless double insulated). If the tool is equipped with an approved 3-conductor cord and a 3-prong grounding type plug to fit the proper grounding type receptacle, the green conductor in the cord is the grounding wire. Never connect the green wire to a live terminal.**
- **Wear proper eye and ear protection. Also, wear a dust mask.**
- **Keep guards in place. Always keep guards in working order and in proper alignment and adjustment. Most injuries occur on unguarded power tools.**
- **Remove adjusting keys and wrenches.**
- **Wear proper apparel. Do not wear loose clothing, ties, gloves, rings or other jewelry. Roll sleeves up above your elbows, wear nonslip footwear, and tuck long hair under a hat.**
- **Do not operate power tools if you are tired, taking medication, or under the influence of alcohol or drugs.**
- **Avoid dangerous environments. Do not use power tools in damp, wet or explosive atmospheres.**
- **Keep work areas well lit, clean, and free from clutter.**
- **Do not force a tool. It will do the job better and safer at the rate for which it was designed.**
- **Use the right tool. Do not try to use a tool or accessory for a job for which it is not designed.**
- **For direction of feed: ALWAYS feed the workpiece into the cutter against the rotation of the cutter. NEVER feed the workpiece into the cutter with the rotation of the cutter.**
- **Check for any damaged parts. A damaged guard or part should be properly repaired or replaced before further use. If a strange noise or vibration develops, immediately turn off the power, unplug the machine and correct the problem. Never operate a power tool that is not functioning properly.**

-
- **Secure your workpieces. When practical, use clamps, fixtures, and other devices to hold workpieces. Use featherboards and push blocks when appropriate. It's safer than using your hands and it frees your hands to operate the tool.**
 - **Do not overreach. Keep proper footing and balance at all times.**
 - **Turn off the tool and wait until it comes to a complete stop before removing workpieces and scraps.**
 - **Do not try to stop the tool by grabbing the workpiece or any part of the tool. Turn off the tool and let it come to a complete stop by itself.**
 - **Do not leave the tool running unattended. Turn off the power. Do not leave the tool until it comes to a complete stop.**
 - **Avoid unintentional starting. Make sure the safety key is removed from the switch before plugging in or unplugging the tool.**
 - **Disconnect your power tools. Turn off and remove the safety key, then unplug the tools before changing accessories and setups, making adjustments, and performing maintenance and repair.**
 - **Do not stand or lean on the tool. You could fall onto the tool or it could tip over, injuring you and/or damaging the tool.**
 - **Maintain your tools. Keep parts and tools sharp, clean and maintained according to the owners manual.**
 - **Make your workshop childproof. Use padlocks, master switches and remove the safety key.**
 - **Keep children away. All visitors should stay a safe distance from power tools, and wear eye and ear protection. No one should be in the work area while you are operating a power tool.**
 - **Do not permit anyone who is inexperienced to use your power tools without supervision.**

SAFETY RULES FOR THE SHOPSMITH POWER STATION

- **Be sure that you read, understand and follow the Owners Manual of each Accessory that you use with the Power Station.**
- **Do not use the Power Station with any type of circular saw blade or any other table saw accessories.**
- **Use only the Accessories with the Power Station which are specified in this Owners Manual and recommended by Shopsmith.**
- **Do not use this Power Station to drive any type of grinding wheel (guarded or unguarded), including the Shopsmith Grinding Wheel Guard Kit.**
- **Use the Power Station with Shopsmith Accessories only. Also use only Shopsmith parts and accessories on your Power Station. Mounting and using non-Shopsmith Accessories on the Shopsmith Power Station, or using non-Shopsmith parts will create a hazardous condition and void your warranty.**
- **Always reduce the speed to its lowest setting before you turn off the Power Station and remove the safety key (35).**
- **Never reach with your hands, tools or any other object beneath the Power Station while it is running.**
- **Always mount the outer shaft cover (40) over the outer drive shaft when the outer drive shaft is not in use.**
- **Whenever operating two separate Accessories on the Power Station, never exceed the maximum operating RPM of the SLOWEST accessory.**
- **Always use dust collection whenever possible.**
- **Always securely lock the Accessory in the Power Station before operating it.**
- **Always be sure the Power Station carriage is locked in position before operating any Accessory with the Power Station.**
- **If you hear a strange noise or vibration during operations, turn off the Power Station, remove the safety key (35) and disconnect the power cord before investigating the noise or vibration.**
- **Do not operate damaged machinery.**
- **When setting the speed of the Power Station, always securely tighten the speed control knob (41).**
- **Remove the safety key (35) to lock the Power Station in the "off" position when finished with each operation and before servicing the Power Station.**

TERMS TO KNOW

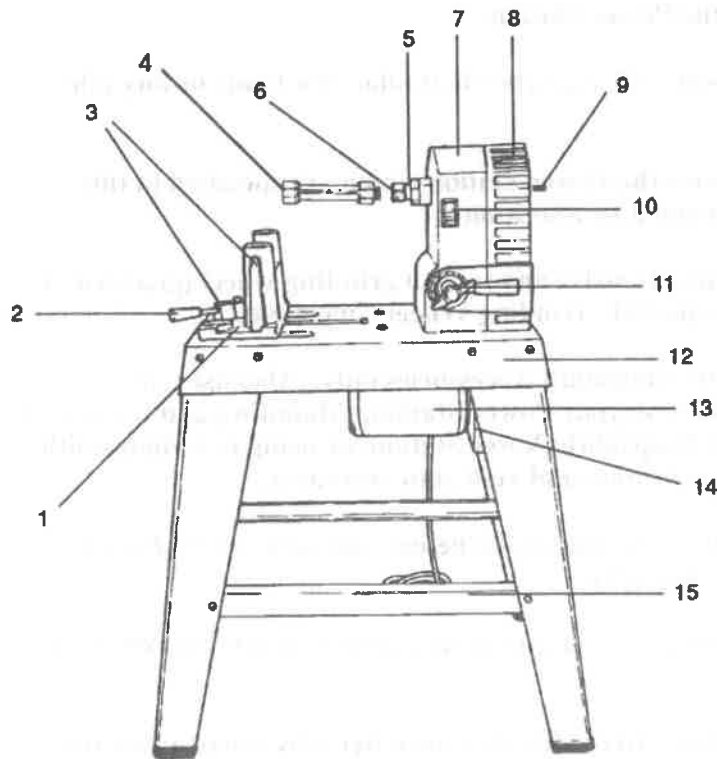

Here are some terms and descriptions for various parts of the Power Station. Knowing them will help you throughout this manual.

1. **Carriage**— The holder of the mounting tubes of a Major Accessory or Extension Table. It slides forward to engage the Power Station hub (via the coupler), and slides back to disengage. The tall holes are for mounting the Jointer, Scroll Saw and Extension Table. The short holes are for the Bandsaw, Strip Sander, Belt Sander and Jigsaw.

2. **Carriage Lock**— Turn the handle to the right to lock the carriage in place, and turn it to the left to unlock it.

3. **Setscrews**— Used to secure the Major Accessory or Extension Table mounting tubes to the Power Station's carriage. Supplied is a 5/32" Allen wrench.

4. **Power Coupler**— Connects the Power Station Hub to the Major Accessory Hub in order to transfer power to a Major Accessory.

5. **Drive Shaft**-- Delivers power to Major Accessories and other minor accessories.

6. **Drive Shaft Hub**-- connects the Power Station with the Major Accessories via the power coupler.

7. **Headstock--** transfers the motor power to the drive shaft through a variable speed mechanism.
8. **Housing Cover--** covers belts and pulleys above the base.
9. **Outer Drive Shaft—** allows you to power various tools from the outer side of the headstock, and to perform two functions at the same time— one attached to the main, inside drive shaft and one attached to the outer drive shaft. When not in use, it should be covered by the Outer Shaft Cover, which is installed by inserting it over the Outer Drive Shaft, into the Housing Cover, then gently twisting it to the right until it engages the notches in the Housing Cover.
10. **Lockable Power Switch—** turns the machine on and off, and can be locked in the “off” position by removing the safety key.
11. **Motor Speed Dial—** adjusts the drive shaft from 850* to 3,850* rpms- a wide range of speeds to accommodate a variety of accessories performing different tasks.
12. **Base--** supports the Headstock, Motor and Carriage.
13. **Motor—**3/4 hp continuous. 10 Amp.
14. **Belt & Pulley Guard--** covers belts and pulleys below the base.
15. **Leg Braces--** add rigidity and stability to the Power Station.
16. **Optional Retractable Casters—** (not shown). Can be purchased extra. Allows you to more easily move the Power Station, then lock it in place.

SPECIFICATIONS

The Shopsmith Power Station measures 28-1/2" long x 19-1/2" wide x 37-3/4" high and weighs 73 lbs. It can be stored in 5 square feet of floor space.

The heavy duty electric motor is a continuous rated motor that generates 3/4 continuous h.p. at 10 Amps and 115 Volts on 60 Hz electricity. It will develop a maximum of 1 h.p.

**POWER STATION
APPROXIMATE SPEED CHART ***

Dial Setting	RPM
1	850
2	1050
3	1200
4	1450
5	1810
6	2200
7	2650
8	3220
9	3850

*All speeds listed at the various speed settings throughout this manual may vary slightly, due to production variations.

POWER STATION PARTS LIST

Ref. Part No. No.	Description	Qty.	Ref. Part No. No.	Description	Qty.
1 513969	Leg Boot	4	40 515667	Shaft Cover	1
2 160515	Screw, Pan Head, 1/4"-20 x 1/2"	24	41 515662	Knob, Speed Control Clamp	1
3 514204	Hex Nut, 1/4"-20	22	42 515650	Speed Control Lever	1
4 115546	Washer, Star, 1/4"	22	43 515657	Lever Base, Speed Control	1
5 502766-02	Leg	4	44 515640	Bushing	2
6 502769-02	Short Leg Brace	2	45 504259	Retaining Washer	1
7 515888	Long Leg Brace	2	46 515642	Speed Control Shaft	1
8 515770	Belt Guard Assembly (inc. 9)	1	47 515655	Speed Control Label	1
9 515701	. Belt Guard Pad	2	48 515641	Gear	1
10 515744	Tinnerman Nut, 1/4"-20	2	49 515652	Cord	1
11 515771	Base (with label 68)	1	50 502333	Washer, 1/4"	4
12 514527	Rollpin, 5/32" x 7/8"	1	51 515637	Left Guide	1
13 514096	Cam Wedge	1	52 515707	Right Guide	1
14 515724	Clamp	1	53 515635	Rack and Shaft Assembly	1
15 515727	Clamp Shaft	1	54 515120	Taplite Screw	3
16 443334	Nut, Hex Flexlock, 5/16"-24	1	55 515647	Cable Clamp	1
17 120393	Washer, 5/16"	1	56 120392	Washer, 1/4"	2
18 515726	Handle Base	1	57 515880	Screw, Self Tapping, 1/4"-20 x 1/2"	2
19 513058	Handle	1	58 515672	Shaft and Bearing Assembly	1
20 515747	Special Washer	1	59 515627	Variator	1
21 515631	Carriage Assembly (inc. 22)	1	60 515624	Sheave, 4-1/2"	1
22 501634	. Nylock Setscrew, 5/16"-18	4	61 515772	Main Housing (inc. labels 47, 70)	1
23 515623	Motor	1	62 513795	Screw, Socket Head Cap, 5/16"- 18 x 3/4"	4
24 102634	Hex Nut	12	63 102634	Nut, Hex, 5/16"	4
25 115548	Internal Tooth Washer, 5/16"	8	64 115548	Washer, 5/16"	4
26 502081	Washer, 5/8"	8	65 515645	Snap Bushing	1
27 515651	Bolt, 5/16"-18 x 3"	4	66 513740	Strain Relief	1
28 115321	Setscrew, 5/16"-18 x 5/16"	2	67 515633	Belt	2
29 515625	Sheave, 2-1/2"	1	68 515697	Label	2
30 515656	Key	1	69 515209	Logo Label	2
- 503570	Hub Drive Assembly (inc. 31-32)	1	70 515654	Warning Label	1
31 503571M	. Hub	1	71 503574	Power Coupler	1
32 502051	. Setscrew, 5/16"-18 x 3/8"	1	72 515809	Special Washer	1
33 501306	Spindle Knob	1	73 513513	Screw, Socket Head Cap, 10-24 x 5/8"	1
34 102581	Setscrew, 5/16"-18 x 3/8"	1	74 513065	Wire Tie	1
35 515107	Safety Key	1	- 502925	5/32" Short Allen Wrench	1
36 514796	Locking Rocker Switch	1			
37 513386	Screw, Socket 1/4"-20 x 1"	8			
38 502333	Washer, 1/4"	4			
39 515622	Housing Cover	1			

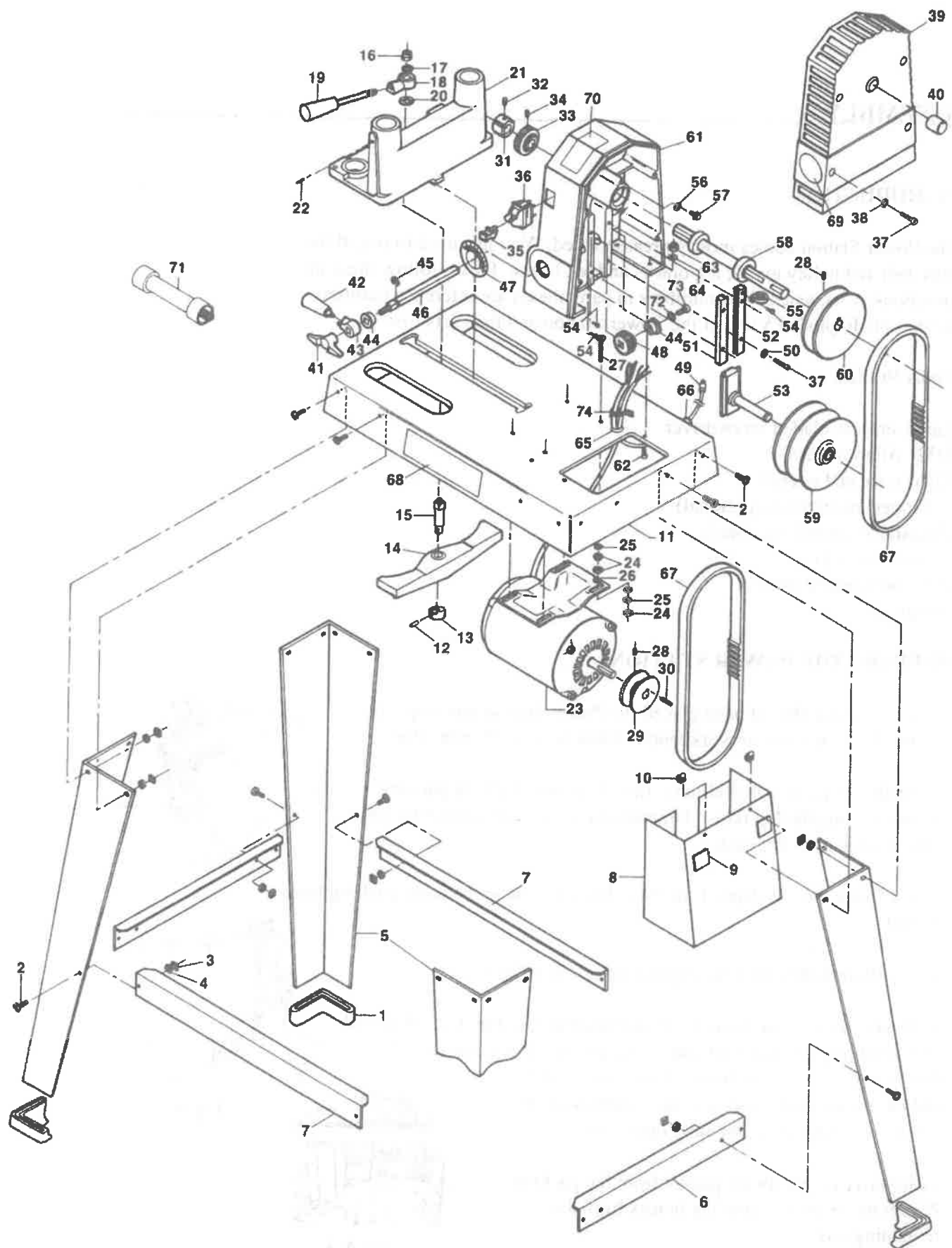

ASSEMBLY

INTRODUCTION

The Power Station comes mostly preassembled. You just need to install the legs, belt and pulley guard, leg braces and leg boots. Please follow these instructions in sequence. The numbers in parentheses are reference numbers used in the Exploded View of the Power Station and the Parts List.

Tools Needed:

Large straight-bladed screwdriver
5/32" Allen wrench
7/16" open end wrench
1/2" open end wrench (optional)
Adjustable wrench (optional)
Pliers (optional)
Paste or furniture Wax
Shop rag

PREPARE THE POWER STATION

1. By now, you should have placed the Power Station box (top-side up) on the floor, table or workbench. Clear your work area, also.
2. Additionally, you should have already removed all the packing staples holding the top flaps. Unremoved staples can scratch and mar a floor, table or workbench.
3. Fold back the top flaps of the box. Do not remove the foam packing from the top.
4. Gently turn the entire box upside down. See Fig.A-1.
5. Slowly lift the box from the Power Station. See Fig.A-2. You will be assembling the legs, belt and pulley guard and leg braces with the Power Station in this position. The foam padding and cardboard gives it support and stability, as in Fig.A-3, during your assembly operations.
6. Remove the hardware packet from the packing. Also remove the legs and leg braces from the remaining box.



Fig.A-1



Fig.A-2

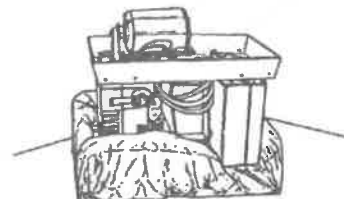

Fig.A-3

INSTALL THE LEGS ON THE HEADSTOCK-END

7. Working on the headstock end of the Power Station, hold a leg (5) in place while inserting a screw (2) through the corner top hole, fastening it with a star washer (4) and a nut (3). See Fig.A-4. Finger tighten. Repeat this for the two side holes. Don't insert a screw in the end inside hole yet.

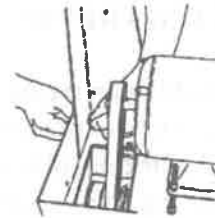

Fig.A-4

8. Repeat Step 7 for the other leg on the headstock end, remembering to leave the end inside hole alone for now. See Fig.A-5.

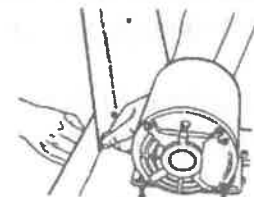

Fig.A-5

INSTALL THE BELT & PULLEY GUARD

9. Slip a Tinnerman nut (10) over each hole in the belt and pulley guard (8), making sure that the nut side faces the inside of the guard. See Fig.A-6.

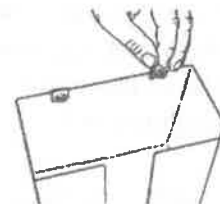

Fig.A-6

NOTE

If the Tinnerman nuts do not hold in place after you have performed Step 9, remove each Tinnerman nut and gently squeeze it's two sides with pliers. This should allow it to snugly grip the belt and pulley guard.

10. Place the belt and pulley guard (8) between the legs, as in Fig.A-7, with the motor drive shaft fitting into the guard's slot.

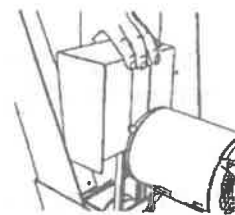

Fig.A-7

11. Thread a screw (2) through the Power Station base (11), leg (5) and the belt and pulley guard (8) on each of the two end inside holes. Finger tighten the screws. See Fig.A-8.

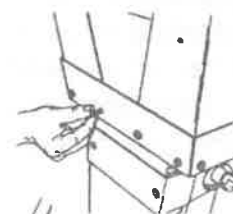

Fig.A-8

INSTALL THE LEGS ON THE CARRIAGE-END

12. Working on the carriage end of the Power Station now, hold a leg in place while you insert a screw (2) through the base (11) and leg (5), securing it with a star washer (4) and a nut (3). Repeat this for each hole. Finger tighten. See Fig.A-9.

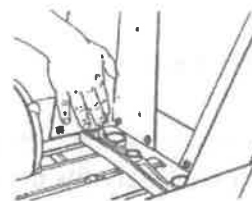

Fig.A-9

13. Repeat Step 12 to install the other leg.

INSTALL THE SHORT LEG BRACES

14. Working on the headstock side of the Power Station, place a short leg brace (6) between the end legs, making sure that the "top ledge" of the leg brace faces toward the motor. See Fig.A-10. Use the leg holes located 10-1/2" from each leg end.

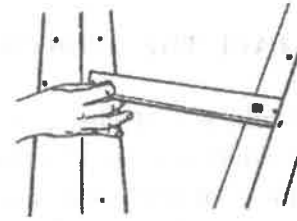

Fig A-10

15. Attach the leg brace (6) to the legs by installing a screw (2), star washer (4) and nut (3) through each inside hole of the short leg brace (6). Finger tighten.

16. Repeat Steps 14 and 15 to install the other short leg brace (6) on the legs located on the carriage end of the Power Station.

INSTALL THE LONG LEG BRACES

17. Place a long leg brace (7) between a carriage-end leg and a headstock-end leg, making sure that the flat "top ledge" of the leg brace faces the motor. Again, use the leg holes located 10-1/2" from each leg end.

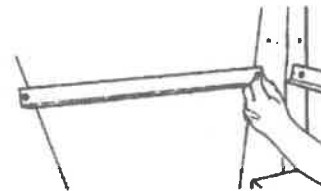

Fig.A-11

18. Attach the long leg brace (7) to the legs by installing a screw (2), star washer (4) and nut (3) in each end. Finger tighten. See Fig.A-11.

19. Repeat Steps 14 and 15 to install the other long leg brace (7) between a carriage-end leg and a headstock-end leg. See Fig.A-12.

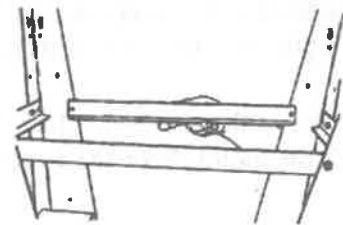

Fig.A-12

SECURELY TIGHTEN ALL NUTS AND SCREWS

20. After you have all the legs, leg braces, pulley and belt guard and hardware installed as described above, securely tighten all the nuts and screws which attach the legs (5) to the base (11). Then tighten all the nuts and screws attaching the leg braces (6 and 7) to the legs (5). See Fig.A-13.

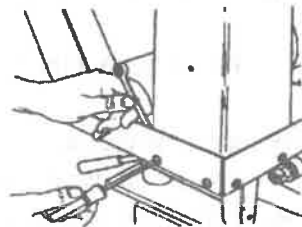

Fig.A-13

INSTALL THE LEG BOOTS

18. Slip a leg boot (1) onto each leg end, gently "working" the leg boot until it snugly fits the leg end. See Fig.A-14.



Fig.A-14

PLACE THE POWER STATION UPRIGHT

19. Carefully place the Power Station upright, as in Fig.A-15.

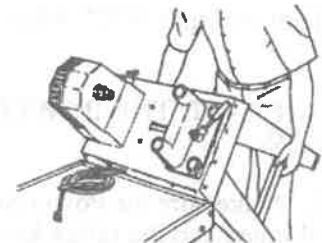

Fig.A-15

WAX THE CARRIAGE PATH AND TUBE HOLES (to help the sliding of the various parts)

20. Using paste or furniture wax (NOT car wax) and a soft cloth, wax the entire carriage slide path. You will need to loosen the carriage lock and slide the carriage forward in order to wax all of the path. Buff off the excess wax. See Figs. A-16 and A-17.

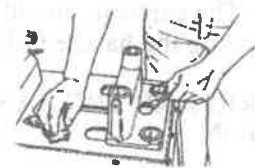

Fig.A-16

21. Wax the inside of each of the four tubeholes in the carriage. See Fig.A-18.

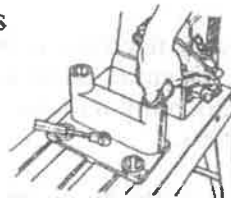

Fig.A-18

ADJUST THE CARRIAGE LOCK NUT

22. The carriage lock nut (16) is adjusted at the factory. However, if the carriage is not locking securely enough (or is too tight), you need to adjust the carriage lock nut (16) with a wrench, as shown in Fig.A-19.



Fig.A-17

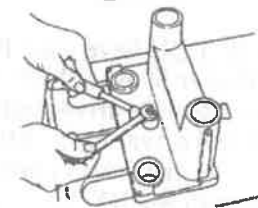

Fig.A-19

AFTER ALL OF THE ABOVE INSTRUCTIONS ARE COMPLETED, THE POWER STATION IS READY FOR INSTALLATION AND ALIGNMENT OF AN ACCESSORY. FOR THOSE INSTRUCTIONS, GO TO THE PAGE LISTED BELOW OF THE ACCESSORY YOU WISH TO USE.

Bandsaw.....	16
Jointer.....	20
Scroll Saw.....	23
Strip Sander.....	27
Belt Sander.....	30
Jig Saw.....	33
Disc Sander.....	36
Drum Sander.....	38
Flutter Sander.....	39
Flexible Shaft.....	40

WARNING

Use only the Accessories with the Power Station which are specified in this Owners Manual. Do not use saw blades, grinding wheels, or any other tools with the Power Station not specifically mentioned in the Power Station Owners Manual.

BANDSAW ALIGNMENT

Tool Needed: 5/32" Allen wrench

PREPARE THE POWER STATION FOR MOUNTING THE BANDSAW

1. Make sure the Power Station is: set at the slowest speed, turned off, unplugged and the safety key (35) is removed from the switch.
2. The carriage should be positioned all the way to the left, and locked by moving the handle (19) to the right.

PREPARE THE BANDSAW FOR MOUNTING ON THE POWER STATION

3. —**IF YOU** have purchased your Bandsaw to be operated with the Shopsmith Power Station, read the entire Bandsaw Owners Manual, including instructions up to the point of mounting it on the Shopsmith MARK V. Then proceed with Step 4 of this section.

—**IF YOU** have your Bandsaw already set up to operate with the Shopsmith MARK V, you are now prepared to mount it on the Power Station. Proceed with Step 4 of this section.

—**IF YOU** have your Bandsaw installed on the Shopsmith Major Accessory Power Stand (513963), remove it from the Power Stand. Remove the pulley from the drive shaft. Also remove the pulley guard bracket, located below the drive shaft. After removing the pulley and the pulley guard bracket, install the drive hub normally used when operating the Bandsaw with the Shopsmith MARK V. Then proceed with Step 4 of this section.

MOUNT THE BANDSAW ON THE POWER STATION

4. Placing your hands on the table and on the middle of the Bandsaw, lift it into the short tube holes in the Power Station carriage, with the drive shaft pointing toward the Power Station headstock. See Fig.B-1. You may need to adjust the Bandsaw's mounting tubes to fit them in the tube holes.

5. Place the power coupler (71) on the Bandsaw's drive hub. See Fig.B-2.

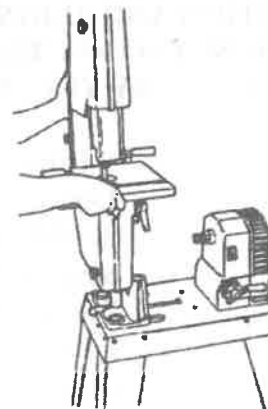

Fig.B-1

NOTE
The coupler **MUST** be on the hub all the way and evenly "squared" on the hub. If not, alignment may be off. Also, vibration and premature coupler wear may result.

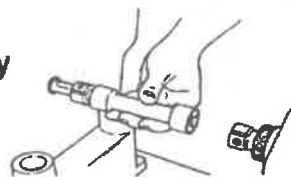

Fig.B-2

6. Unlock the carriage (21) by turning the handle (19) to the left. With your hands placed on the carriage and Bandsaw, slide the carriage toward the Power Station's drive shaft hub (31) until the coupler almost touches the hub. See Fig.B-3.

7. Lock the carriage by turning the handle (19) to the right.

HORIZONTALLY ALIGN THE BANDSAW TO THE POWER STATION'S DRIVE SHAFT HUB

NOTE

This may be a two person job, as it may be more convenient for one person to align the Bandsaw while the other person tightens the setscrews. If a second person is unavailable, then you may need to estimate the adjustment needed, tighten the carriage and Bandsaw setscrews (22), and recheck the alignment.

8. Loosen the two tube locking setscrews in the Bandsaw's lower frame. The setscrews on the carriage should still be loose. See Fig.B-4.

9. Typical misalignment is shown in Fig.B-5. To align the Bandsaw horizontally (whether there are one or two persons—see above note), reach under the Power Station base and twist both eccentric tubes, shown in Fig.B-6, until the coupler is horizontally aligned with the drive shaft hub. After the Bandsaw is horizontally aligned as in Fig.B-7, tighten the carriage setscrews (22). See Fig.B-8.

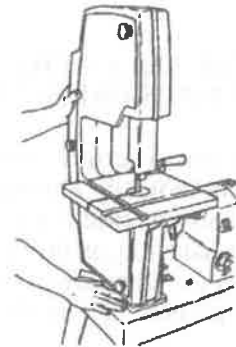

Fig.B-3

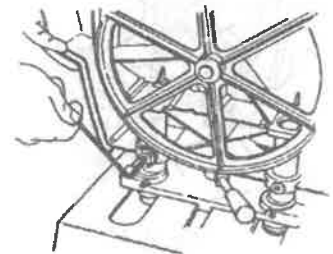

Fig.B-4

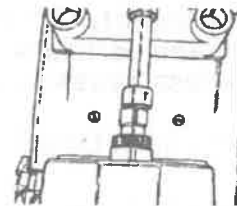

Fig.B-5

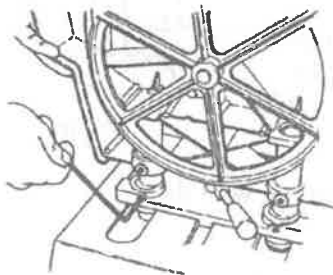

Fig.B-8

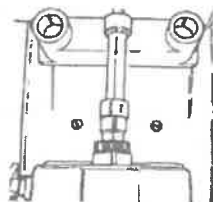

Fig.B-7

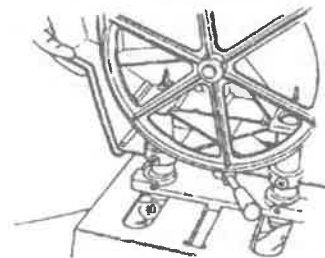

Fig.B-6

VERTICALLY ALIGN THE BANDSAW TO THE POWER STATION'S DRIVE SHAFT HUB

10. Typical vertical misalignment is shown in Fig.B-9. After you have horizontally aligned the Bandsaw to the drive shaft hub (31), lift the Bandsaw (see Fig.B-10) until the coupler vertically aligns with the drive shaft hub, as in Fig.B-11. When they are vertically aligned, tighten the Bandsaw tube setscrews. See Fig.B-12. Recheck the vertical alignment. If it is off, re-do it.

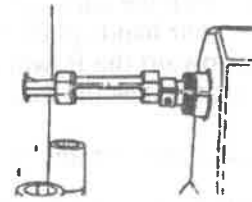

Fig.B-9

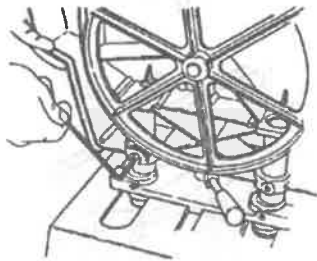

Fig.B-12

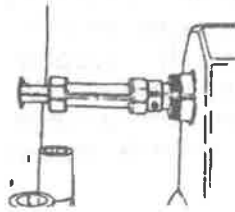

Fig.B-11

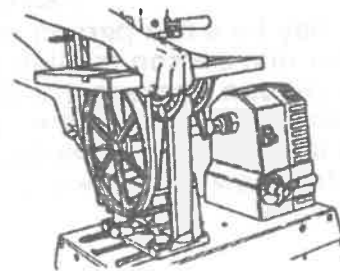

Fig.B-10

CAUTION

It is very important that the two hubs be aligned both horizontally and vertically, so that the coupler does not experience stress caused by misalignment.

PREPARE FOR OPERATIONS

11. Make sure all four setscrews on both the Bandsaw and the Power Station carriage are securely tightened.

12. Line up the notches in the drive shaft hub with the ridges inside the coupler. Unlock the carriage, and with one hand on the carriage and another near the middle of the Bandsaw, slide the carriage so that the coupler on the Bandsaw fits over the drive shaft hub (31). See Fig.B-13.

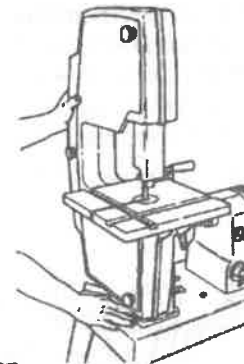

Fig.B-13

13. After you have securely connected the Bandsaw to the Power Station with the coupler, lock the carriage (21) by turning the handle (19) to the right.

14. Plug in the Power Station and insert the safety key. You are now ready to operate the Bandsaw with the Power Station.

BANDSAW OPERATIONS--

WARNING

Read the "Safety" and "Operations" sections in your Shopsmith Bandsaw Owners Manual before operating the Bandsaw with the Power Station. Additional information and instructions are provided in the text, Power Tool Woodworking For Everyone. If you have questions, call or write Customer Service at the addresses and phone numbers listed on the back cover of this manual.

POWER STATION SPEED SETTINGS FOR USING THE BANDSAW

The following is a chart of recommended Power Station speed settings to use with the Bandsaw:

BLADE SIZE	HARDWOOD		SOFTWOOD	
	RPM	P.S. SETTING	RPM	P.S. SETTING
1/16"	950	1-1/2	1050	2
1/8"	950	1-1/2	1050	2
1/4"	850	1	950	1-1/2
1/2"	850	1	850	1
5/8"	850	1	850	1

JOINTER ALIGNMENT

Tool Needed:

5/32" Allen wrench

PREPARE THE POWER STATION FOR MOUNTING THE JOINTER

1. Make sure the Power Station is: set at its slowest speed, turned off, unplugged and the safety key (35) removed from the switch.
2. The carriage (21) should be positioned all the way to the left, and locked by moving the handle (19) to the right.

PREPARE THE JOINTER FOR MOUNTING ON THE POWER STATION

3. —**IF YOU** have purchased your Jointer to be operated with the Shopsmith Power Station, read and understand the entire Jointer Owners Manual, including the instructions up to the point of mounting it on the Shopsmith MARK V. Then proceed with Step 4 of this section.

—**IF YOU** have your Jointer already set up to operate with the Shopsmith MARK V, you are now prepared to mount it on the Power Station. Proceed with Step 4 of this section.

—**IF YOU** have your Jointer installed on the Shopsmith Major Accessory Power Stand (513963), you will need to remove the pulley from the power shaft. After removing the pulley and the pulley guard bracket, install the drive shaft hub normally used when operating the Jointer with the Shopsmith MARK V. Then proceed with Step 4 of this section.

MOUNT THE JOINTER ON THE POWER STATION

4. Insert the Jointer tubes into the tall holes of the Power Station carriage (21), with the Jointer's drive shaft pointed toward the Power Station headstock. See Fig.C-1. You may need to adjust the Jointer's tubes to fit them in the tube holes.
5. Place the power coupler (71) onto the Jointer's drive shaft hub, as in Fig.C-2.

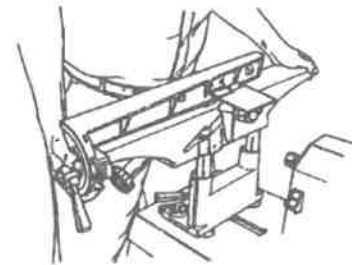

Fig.C-1

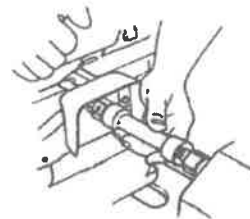

Fig.C-2

NOTE

The coupler **MUST** be on the hub all the way and evenly "squared" on the hub. If it is not, alignment may be off. Also, vibration and premature coupler wear may result.

6. Unlock the carriage (21) by turning the handle (19) to the left. With your hands placed on the carriage and the Jointer, slide the carriage and Jointer toward the Power Station's drive shaft hub (31) until the coupler almost touches the hub. See Fig.C-3.

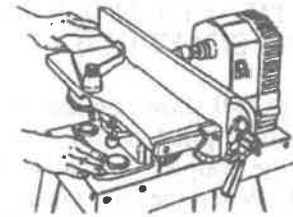

Fig.C-3

7. Lock the carriage by turning the handle (19) to the right.

HORIZONTALLY ALIGN THE JOINTER TO THE POWER STATION'S DRIVE SHAFT HUB

8. Loosen the two setscrews which lock the Jointer casting to the Jointer's mounting tubes. The setscrews on the carriage should still be loose. See Fig.C-4.

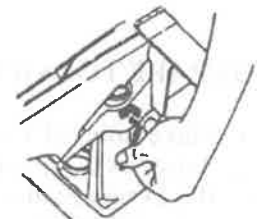

Fig.C-4

9. To align the Jointer horizontally, look to see how much it is out of horizontal alignment. Fig.C-5 shows typical misalignment. Then lift the Jointer from the carriage (21) leaving the Jointer tubes in the carriage tube holes.

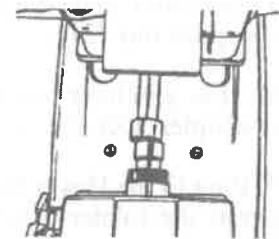

Fig.C-5

10. Twist the tubes, as in Fig.C-6, to either the left or right by the amount you judge is needed to bring the coupler in horizontal alignment with the drive shaft hub (31). When you move the tubes make sure you move them parallel to each other. It will make it easier when you remount the Jointer and you will be more accurate in your adjustment.

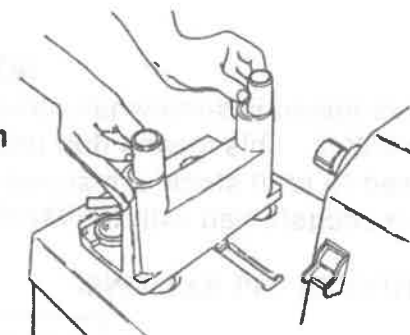

Fig.C-6

11. Remount the Jointer on its tubes. Check the horizontal alignment again. If it is still not aligned, repeat Steps 9 and 10 until you achieve it. Fig.C-7 shows alignment.

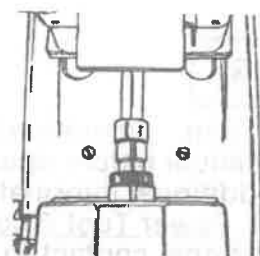

Fig.C-7

12. When you have horizontally aligned the Jointer to the Power Station, tighten both of the carriage's setscrews (22), securing the Jointer tubes, as shown in Fig.C-8.



It is very important that the two hubs be aligned both horizontally and vertically, so that the coupler does not experience stress caused by misalignment.

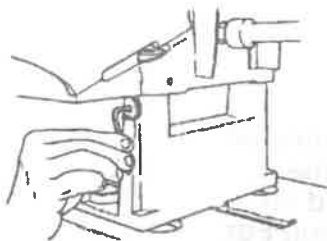

Fig.C-8

VERTICALLY ALIGN THE JOINTER TO THE POWER STATION'S DRIVE SHAFT HUB

13. Fig.C-9 shows typical vertical misalignment. After you have horizontally aligned the Jointer to the drive shaft hub (31), lift the Jointer until the coupler vertically aligns with the drive shaft hub, as in Fig. C-10. When they are vertically aligned, tighten the Jointer tube setscrews. See Fig.C-11. Recheck the vertical alignment. If it is off, re-do it.

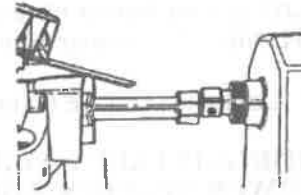

Fig.C-9

PREPARE FOR OPERATIONS

14. Make sure all four tube locking setscrews in both the Jointer and the Power Station carriage are securely tightened.

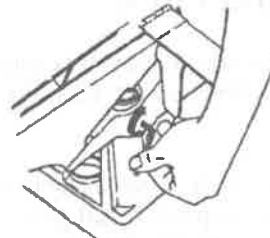

Fig.C-11

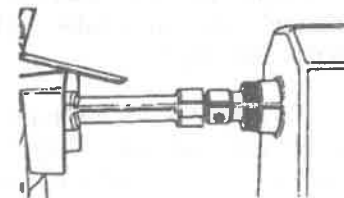

Fig.C-10

15. Line up the notches on the drive shaft hub with the ridges inside the coupler. Unlock the carriage, and with one hand on the carriage and another on the Jointer, slide the carriage so that the coupler on the Jointer fits over the drive shaft hub (31).

16. After you have securely connected the Jointer to the Power Station with the coupler, lock the carriage (21) by turning the handle (19) to the right.

17. Plug in the Power Station and insert the safety key. You are now ready to operate the Jointer with the Power Station.

POWER STATION SPEED SETTINGS FOR USING THE JOINTER

Set the Power Station speed setting to 3850 rpm (the fastest speed setting of "9") for all Jointer operations.

NOTE

This speed is somewhat slower than the Jointer speed on the Shopsmith MARK V. This means that users of the Jointer with the MARK V may need to joint stock at a slower feed rate with the Power Station than they are accustomed with the MARK V.

JOINTER OPERATIONS-

WARNING

Read and understand the "Safety" and "Operations" sections of your Shopsmith Jointer Owners Manual before operating the Jointer with the Power Station. Additional information and instructions are provided in the text, Power Tool Woodworking For Everyone. If you have further questions, contact Customer Service as indicated on the back cover of this manual.

SCROLL SAW ALIGNMENT

Tool Needed: 5/32" Allen wrench

PREPARE THE POWER STATION FOR MOUNTING THE SCROLL SAW

1. Make sure the Power Station is: set to its slowest speed, turned off, unplugged and the safety key (31) removed from the switch.
2. The carriage (21) should be positioned all the way to the left, and locked by moving the handle (19) to the right.

PREPARE THE SCROLL SAW FOR MOUNTING ON THE POWER STATION

3. —IF YOU have purchased your Scroll Saw to be operated with the Shopsmith Power Station, read and understand the Scroll Saw Owners Manual, including following the instructions up to the point of mounting it on the Shopsmith MARK V. Then proceed with Step 4 of this section.

—IF YOU have your Scroll Saw already set up to operate with the Shopsmith MARK V, you are now prepared to mount it on the Power Station. Proceed with Step 4 of this section.

—IF YOU have your Scroll Saw installed on the Shopsmith Major Accessory Power Stand (513963), you will need to remove the pulley from the power shaft. After removing the pulley, install the drive hub normally used when operating the Scroll Saw with the Shopsmith MARK V. Then proceed with Step 4 of this section.

MOUNT THE SCROLL SAW ON THE POWER STATION

4. Insert the Scroll Saw tubes into the tall holes of the Power Station carriage (21), with the Scroll Saw's drive shaft pointed toward the Power Station headstock. See Fig.D-1. You may need to adjust the Scroll Saw's tubes to fit them in the tube holes.
5. Place the power coupler (71) onto the Scroll Saw's drive shaft hub, as in Fig.D-2.

NOTE

The coupler MUST be on the hub all the way and evenly "squared" on the hub. If it is not, alignment may be off. Also, vibration and premature coupler wear may occur.

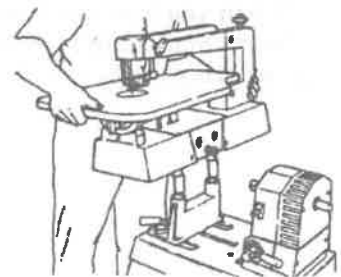

Fig.D-1

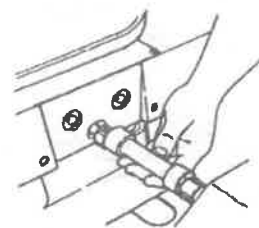

Fig.D-2

6. Unlock the carriage (21) by turning the handle (19) to the left. With your hands placed on the carriage and the Scroll Saw, slide the carriage and Scroll Saw toward the Power Station's drive shaft hub (31) until the coupler almost touches the hub. See Fig.D-3.

7. Lock the carriage by turning the handle (19) to the right.

HORIZONTALLY ALIGN THE SCROLL SAW TO THE POWER STATION'S DRIVE SHAFT HUB

8. Fig.D-4 shows typical horizontal misalignment. Loosen the two setscrews on the Scroll Saw's tubes, as in Fig.D-5. The setscrews on the carriage's tall tube holes should still be loose, also.

9. To align the Scroll Saw horizontally, look to see how much you are out of horizontal alignment. Then lift the Scroll Saw from the carriage (21) leaving the Scroll Saw tubes in the carriage tube holes.

10. Twist the tubes to either the left or right by the amount you judge is needed to bring the coupler in horizontal alignment with the drive shaft hub (31). See Fig.D-6. When you move the tubes make sure you move them parallel to each other. It will make it easier when you rere-mount the Scroll Saw, and you will be more accurate in your adjustment, as in Fig.D-7.

11. Remount the Scroll Saw on its tubes. Check the horizontal alignment again. If it is still not aligned, repeat Steps 9 and 10 until you achieve it.

12. When you have horizontally aligned the Scroll Saw to the Power Station, tighten both of the carriage's setscrews (22), securing the Scroll Saw tubes. See Fig.D-8.

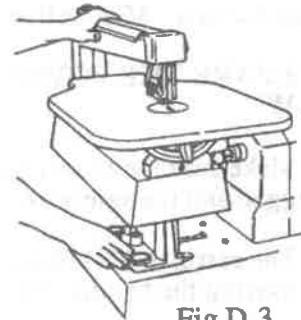

Fig.D-3

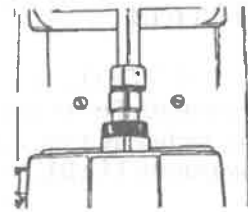

Fig.D-4

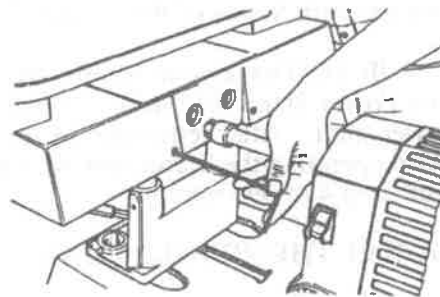

Fig.D-5

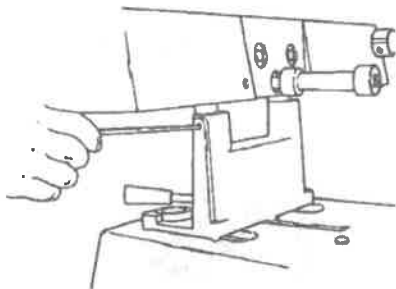

Fig.D-8

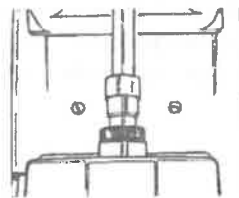

Fig.D-7

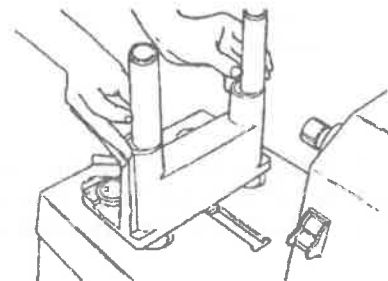

Fig.D-6

VERTICALLY ALIGN THE SCROLL SAW TO THE POWER STATION'S DRIVE SHAFT HUB

13. Fig.D-9 shows typical vertical misalignment. After you have horizontally aligned the Scroll Saw to the drive shaft hub (31), lift the Scroll Saw until the coupler vertically aligns with the drive shaft hub. See Fig.D-10. When they are vertically aligned as in Fig D-11, tighten the Scroll Saw tube setscrews. Recheck the vertical alignment. If it is off, re-do it.

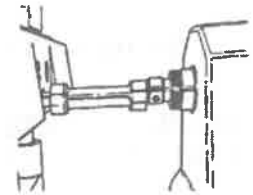

Fig.D-9

CAUTION

It is very important that the two hubs be aligned both horizontally and vertically, so that the coupler does not experience stress caused by misalignment.

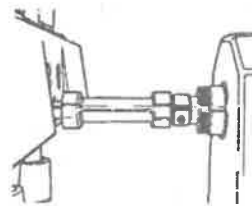

Fig.D-11

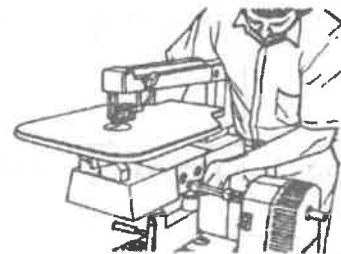

Fig.D-10

PREPARE FOR OPERATIONS

14. Make sure all tube locking setscrews on both the Scroll Saw and the Power Station carriage are securely tightened.

15. Line up the notches on the drive shaft hub with the ridges inside the coupler. Unlock the carriage, and with one hand on the carriage and another on the Scroll Saw, slide the carriage so that the coupler on the Scroll Saw fits over the drive shaft hub (31). See Fig.D-12.

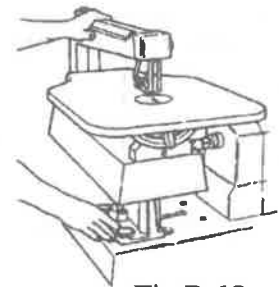

Fig.D-12

16. After you have securely connected the Scroll Saw to the Power Station with the coupler, lock the carriage (21) by turning the handle (19) to the right.

17. Plug in the Power Station and insert the safety key (35). You are now ready to operate the Scroll Saw with the Power Station.

SCROLL SAW OPERATIONS-

WARNING

Read and understand the "Safety" and "Operations" sections of your Shopsmith Scroll Saw Owners Manual before operating it with the Power Station. Additional information and instructions are provided in the text, Power Tool Woodworking For Everyone. If you have further questions, contact Customer Service as indicated on the back cover of this manual.

POWER STATION SPEED SETTINGS FOR USING THE SCROLL SAW

BLADE PART NO.	SPEED RANGE		STROKES/MINUTE	USE TO CUT	STOCK THICKNESS RANGE
	RPM	P.S. SETTING			
555265	850-3850	1- 9	212- 963	Hard & Soft Wood, Plywood, Plastic	1/4" - 2"
555366	850-2790	1- 7-1/4	212- 698	Hard & Soft Wood, Plywood, Plastic, Paper, Felt, Bone	1/8" 1 1/4"
555262	850-3700	1- 8-3/4	212- 925		1/16" - 1"
555263	850-3850	1- 9	212- 963	Hard & Soft Wood, Plywood, Plastic, Bone, Horn, Paper	1/32" - 3/4"
555264	850-3850	1- 9	212- 963	Hard & Soft Wood, Veneer, Bone, Fiber, Ivory, Plastic, Mother-of-Pearl	1/64" - 1/4"
505767	850-2530	1- 6-3/4	212- 633	Hard & Soft Wood, Veneer, Bone, Fiber, Ivory, Plastic, Mother-of-Pearl Non-Ferrous Metal	.020" - 1/8"
505766	850-2200	1- 6	212- 550		.015" - 1/8"
555364 555365 555361 555362 555363	850-1900	1- 5-1/2	212- 475		.010" - 1/8"

STRIP SANDER ALIGNMENT

Tool Needed: 5/32" Allen wrench

PREPARE THE STRIP SANDER FOR MOUNTING ON THE POWER STATION

1. Make sure the Power Station is: set at its slowest speed, turned off, unplugged and the safety key (35) removed from the switch.
2. The carriage (21) should be positioned all the way to the left, and locked by moving the handle (19) to the right.

PREPARE THE STRIP SANDER FOR MOUNTING ON THE POWER STATION

3. —IF YOU have purchased your Strip Sander to be operated with the Shopsmith Power Station, read and understand the entire Strip Sander Owners Manual, including the instructions up to the point of mounting it on the Shopsmith MARK V. Then proceed with Step 4 of this section.

—IF YOU have your Strip Sander already set up to operate with the Shopsmith MARK V, you are now prepared to mount it on the Power Station. Proceed with Step 4 of this section.

—IF YOU have your Strip Sander installed on the Shopsmith Major Accessory Power Stand (513963), you will need to remove the pulley from the drive shaft. After removing the pulley and the pulley guard bracket, install the power shaft hub normally used when operating the Strip Sander with the Shopsmith MARK V. Then proceed with Step 4 of this section.

MOUNT THE STRIP SANDER ON THE POWER STATION

4. Placing your hands on the table and on the middle of the Strip Sander frame, lift it into the short holes in the Power Station carriage, with the drive shaft pointed toward the Power Station headstock. See Fig.E-1. You may need to adjust the Strip Sander's tubes to fit them in the tube holes.

5. Place the power coupler (71) onto the Strip Sander's drive shaft hub, as in Fig.E-2.

NOTE

The coupler **MUST** be on the hub all the way and evenly "squared" on the hub. If it is not, alignment may be off. Also, vibration and premature coupler wear may result.

6. Unlock the carriage (21) by turning the handle (19) to the left. With your hands placed on the carriage and Strip Sander, slide the carriage and Strip Sander toward the Power Station's drive shaft hub (31) until the coupler almost touches the hub.

7. Lock the carriage by turning the handle (19) to the right.

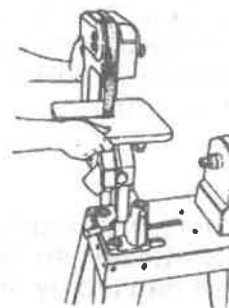

Fig.E-1

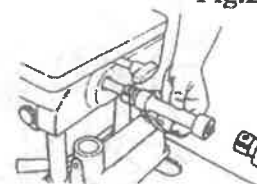

Fig.E-2

HORIZONTALLY ALIGN THE STRIP SANDER TO THE POWER STATION'S DRIVE SHAFT HUB

8. Loosen the two tube locking setscrews in the Strip Sander's main frame. See Fig.E-3. The setscrews on the carriage's short tube holes should still be loose, also.

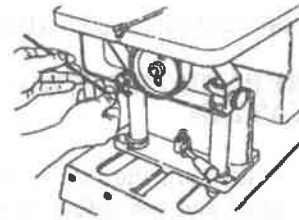

Fig.E-3

9. To align the Strip Sander horizontally, look to see how much it is out of horizontal alignment as shown in Fig.E-4. Then twist the tubes to the left or right until the coupler is aligned with the drive shaft hub. See Fig.E-5.

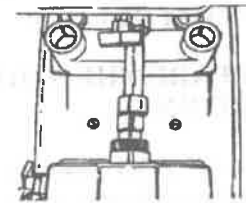

Fig.E-4

10. When it is horizontally aligned (Fig.E-6), tighten the carriage setscrews (22) as in Fig.E-7, securing the Strip Sander tubes.

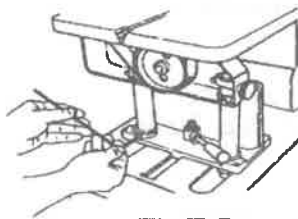

Fig.E-7

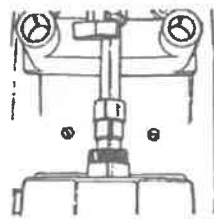

Fig.E-6

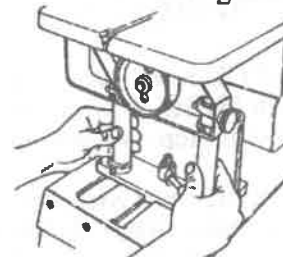

Fig.E-5

VERTICALLY ALIGN THE STRIP SANDER TO THE POWER STATION'S DRIVE SHAFT HUB

11. Fig.E-8 shows typical vertical misalignment. After you have horizontally aligned the Strip Sander to the drive shaft hub (31), lift the Strip Sander as in Fig.E-9, until the coupler vertically aligns with the drive shaft hub. When they are vertically aligned, shown in Fig.E-10, tighten the Strip Sander tube setscrews. See Fig.E-11. Recheck the vertical alignment. If it is off, re-do it.

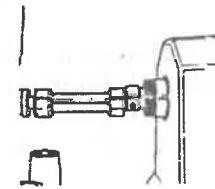

Fig.E-8



It is very important that the two hubs be aligned both horizontally and vertically, so that the coupler does not experience stress caused by misalignment.

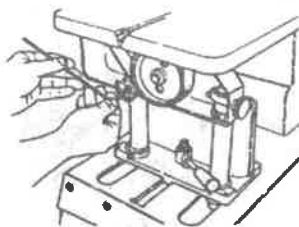

Fig.E-11

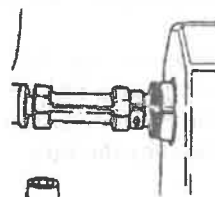

Fig.E-10

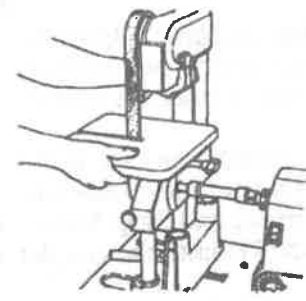

Fig.E-9

PREPARE FOR OPERATIONS

12. Make sure all tube locking setscrews on both the Strip Sander and the Power Station carriage are securely tightened.

13. Line up the notches on the drive shaft hub with the ridges inside the coupler. Unlock the carriage, and with one hand on the carriage and another on the Strip Sander, slide the carriage so that the coupler on the Strip Sander fits over the drive shaft hub (31). See Fig.E-12.

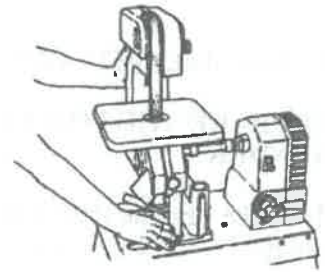

Fig.E-12

14. After you have securely connected the Strip Sander to the Power Station with the coupler, lock the carriage (21) by turning the handle (19) to the right.

15. Plug in the Power Station and insert the safety key (35). You are now ready to operate the Strip Sander with the Power Station.

POWER STATION SPEED SETTINGS FOR THE STRIP SANDER

The following is a chart of recommended Power Station speed settings to use with the Strip Sander:

GRIT TYPE	SIZE	SPEED		MATERIALS WORKED			
		RPM*	P.S. SETTING	Wood		Metals	Plastics*
				Hard	Soft		
Garnet	80	850-1150	1- 2-1/2	x	x	x	
	100	850-1450	1- 4	x	x	x	
	150	1050-1750	2- 4-3/4	x	x	x	
	220	1300-2050	3-1/2- 5-3/4	x	x	x	
Aluminum Oxide	60	850-1450	1- 4	x	x	x	x
	80	850-1560	1- 4-1/4	x	x	x	x
	150	1050-1750	2- 4-3/4	x	x	x	x
	220	1300-1900	3-1/2- 5-1/4	x	x	x	x
	320	1560-2050	4-1/4- 5-3/4	x		x	
	400	1150-1750	2-1/2- 4-3/4	x		x	
Silicone Carbide	600	950-1450	1-1/2- 4			x	
Polish**		850-1150	1- 2-3/4			x	x

* Plastics are always worked at 850 rpm, a Power Station setting of "1".

** Use the appropriate polishing compound for the material being worked.

STRIP SANDER OPERATIONS--

WARNING

Read and understand the "Safety" and "Operations" sections of your Shopsmith Strip Sander Owners Manual before operating it with the Power Station. Additional information and instructions are provided in the text, Power Tool Woodworking For Everyone. If you have further questions, contact Customer Service as indicated on the back cover of this manual.

BELT SANDER ALIGNMENT

Tool Needed: 5/32" Allen wrench

PREPARE THE POWER STATION FOR MOUNTING THE BELT SANDER

1. Make sure the Power Station is: turned to its slowest speed, turned off, unplugged and the safety key (35) removed from the switch.
2. The carriage (21) should be positioned all the way to the left, and locked by moving the handle (19) to the right.

PREPARE THE BELT SANDER FOR MOUNTING ON THE POWER STATION

3. —IF YOU have purchased your Belt Sander to be operated with the Shopsmith Power Station, read and understand the entire Belt Sander Owners Manual, including the instructions up to the point of mounting it on the Shopsmith MARK V. Then proceed with Step 4 of this section.

—IF YOU have your Belt Sander already set up to operate with the Shopsmith MARK V, you are now prepared to mount it on the Power Station. Proceed with Step 4 of this section.

—IF YOU have your Belt Sander installed on the Shopsmith Major Accessory Power Stand (513963), you will need to remove the pulley from the drive shaft. Also remove the pulley guard bracket, located below the power shaft. After removing the pulley and the pulley guard bracket, install the drive shaft hub normally used when operating the Belt Sander with the Shopsmith MARK V. Then proceed with Step 4 of this section.

MOUNT THE BELT SANDER ON THE POWER STATION

4. Insert the Belt Sander mounting tubes into the short holes of the Power Station carriage (21), with the Belt Sander's drive shaft pointed toward the Power Station headstock. You may need to adjust the Belt Sander's tubes to fit them in the tube holes. See Fig.F-1.
5. Place the power coupler (71) onto the Belt Sander's drive shaft hub (31), as in Fig.F-2.

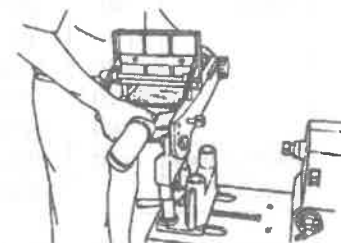

Fig.F-1

NOTE

The coupler **MUST** be on the hub all the way and evenly "squared" on the hub. If it is not, alignment may be off. Also, vibration and premature coupler wear may result.

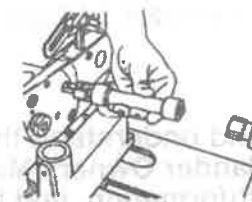

Fig.F-2

6. Unlock the carriage (21) by turning the handle (19) to the left. With your hands placed on the carriage and Belt Sander, slide the carriage and Belt Sander toward the Power Station's drive shaft hub (31) until the coupler almost touches the hub. See Fig.F-3.

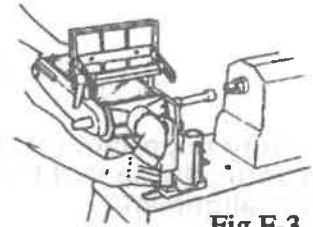

Fig.F-3

7. Lock the carriage by turning the handle (19) to the right.

HORIZONTALLY ALIGN THE BELT SANDER TO THE POWER STATION'S DRIVE SHAFT HUB

8. Loosen the two setscrews in the Belt Sander which lock in the tubes. The setscrews on the carriage should still be loose. See Fig.F-4.

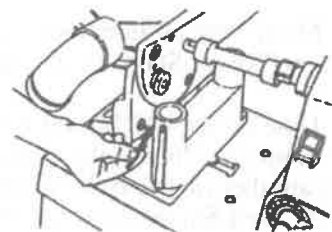

Fig.F-4

9. To align the Belt Sander horizontally, look to see how much it is out of horizontal alignment, like in Fig.F-5. Then twist the tubes to the left or right until the coupler is aligned with the drive shaft hub. See Fig.F-6.

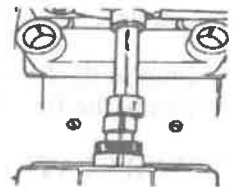

Fig.F-5

10. When you have reached horizontal alignment as in Fig.F-7, tighten the carriage setscrews (22), securing the Belt Sander tubes. See Fig.F-8.

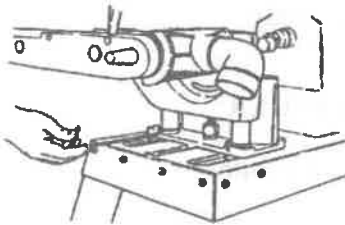

Fig.F-8

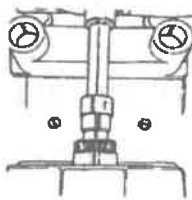

Fig.F-7

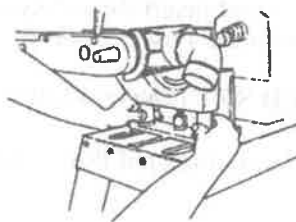

Fig.F-6

VERTICALLY ALIGN THE BELT SANDER TO THE POWER STATION'S DRIVE SHAFT HUB

11. Fig.F-9 shows typical vertical misalignment. After you have horizontally aligned the Belt Sander to the drive shaft hub (31), lift the Belt Sander, as in Fig.F-10, until the coupler vertically aligns with the drive shaft hub. When they are vertically aligned, as in Fig.F-11, tighten the Belt Sander tube setscrews. See Fig.F-12. Recheck the vertical alignment. If it is off, re-do it.

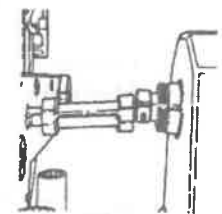

Fig.F-9

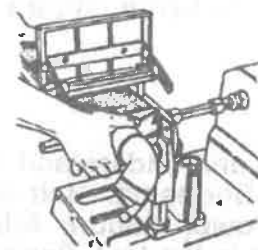

Fig.F-10

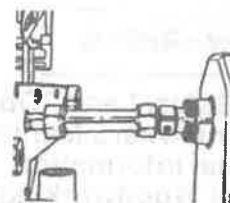

Fig.F-11

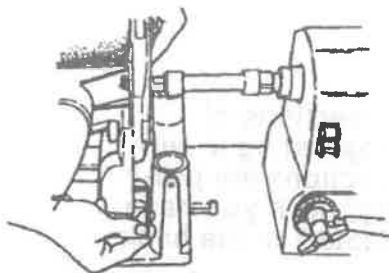

Fig.F-12



It is very important that the two hubs be aligned both horizontally and vertically so that the coupler does not experience stress caused by misalignment.

PREPARE FOR OPERATIONS

12. Make sure all tube locking setscrews on both the Belt Sander and the Power Station carriage are securely tightened.

13. Line up the notches on the drive shaft hub with the ridges inside the coupler. Unlock the carriage, and with one hand on the carriage and another on the Belt Sander, slide the carriage so that the coupler on the Belt Sander fits over the drive shaft hub (31). See Fig.F-13.

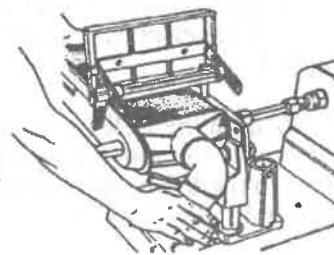

Fig.F-13

14. After you have securely connected the Belt Sander to the Power Station with the coupler, lock the carriage (21) by turning the handle (19) to the right.

15. Plug in the Power Station and insert the safety key (35). You are now ready to operate the Belt Sander with the Power Station

POWER STATION SPEED SETTINGS FOR USING THE BELT SANDER

The following is a chart of recommended Power Station speed settings to use with the Belt Sander:

GRIT	HARDWOOD		SOFTWOOD	
	RPM	P.S. SETTING	RPM	P.S. SETTING
Coarse	1560	4-1/4	1750	4-3/4
Medium	1750	4-3/4	1900	5-1/4
Fine	1900	5-1/4	2050	5-3/4
GRINDING METAL				
Fine	850	1		

BELT SANDER OPERATIONS-



Read and understand the "Safety" and "Operations" sections of your Shopsmith Belt Sander Owners Manual before operating it with the Power Station. Additional information and instructions are provided in the text, Power Tool Woodworking For Everyone. If you have further questions, contact Customer Service as indicated on the back cover of this manual.

JIGSAW ALIGNMENT

Tool Needed: 5/32" Allen wrench

PREPARE THE POWER STATION FOR MOUNTING THE JIGSAW

1. Make sure the Power Station is: turned to its slowest speed, turned off, unplugged and the safety key (35) is removed from the switch.
2. The carriage (21) should be positioned all the way to the left, and locked by moving the handle (19) to the right.

PREPARE THE JIGSAW FOR MOUNTING ON THE POWER STATION

3. —**IF YOU** have your Jigsaw already set up to operate with the Shopsmith MARK V, you are now prepared to mount it on the Power Station. Proceed with Step 4 of this section.

—**IF YOU** have your Jigsaw installed on the Shopsmith Major Accessory Power Stand (513963), you will need to remove the pulley from the power shaft. Also remove the pulley guard bracket, located near the power shaft. After removing the pulley and the pulley guard bracket, install the power shaft hub normally used when operating the Jigsaw with the Shopsmith MARK V. Then proceed with Step 4 of this section.

MOUNT THE JIGSAW ON THE POWER STATION

4. Insert the Jigsaw into the short holes of the Power Station carriage (21), with the Jigsaw's drive shaft pointed toward the Power Station headstock. See Fig G-1. You may need to adjust the Jigsaw's tubes to fit them into the holes.
5. Place the power coupler (71) onto the Jigsaw's drive shaft hub, as in Fig.G-2.

NOTE

The coupler MUST be on the hub all the way and evenly "squared" on the hub. If it is not, alignment may be off. Also, vibration and premature coupler wear may result.

6. Unlock the carriage (21) by turning the handle (19) to the left. With your hands placed on the carriage and Jigsaw, slide the carriage and Jigsaw toward the Power Station's drive shaft hub (31) until the coupler almost touches the hub. See Fig.G-3.

7. Lock the carriage by turning the handle (19) to the right.

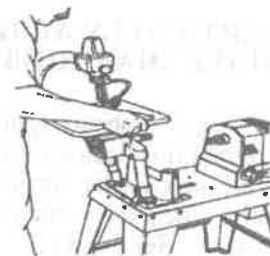

Fig.G-1

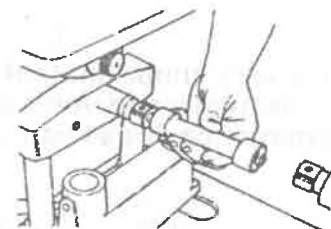

Fig.G-2

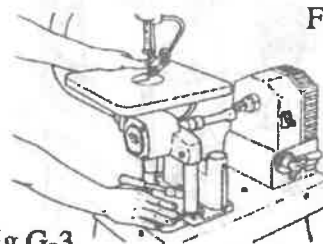

Fig.G-3

HORIZONTALLY ALIGN THE JIGSAW TO THE POWER STATION'S DRIVE SHAFT HUB

8. Loosen the two setscrews holding the Jigsaw's eccentric tubes. (If your Jigsaw does not have eccentric tubes, you must buy them in order to use your Jigsaw with the Power Station. See the back cover of this manual for order information.) See Fig.G-4. The setscrews on the carriage should still be loose, also.

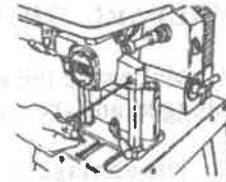

Fig.G-4

9. To align the Jigsaw horizontally, look to see how much you are out of horizontal alignment (as in Fig.G-5). Then twist the tubes to the left or right until the coupler is aligned with the drive shaft hub. See Fig.G-6.

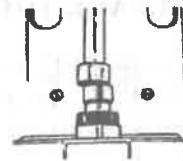

Fig.G-5

10. When you have reached horizontal alignment shown in Fig.G-7, tighten the carriage setscrews (22), securing the Jigsaw tubes. See Fig.G-8.

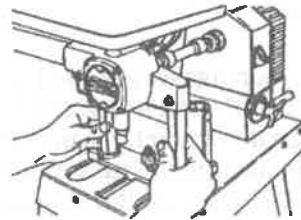

Fig.G-6

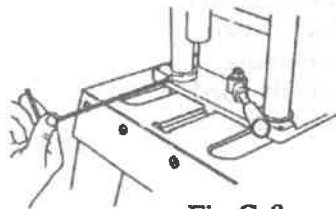

Fig.G-8

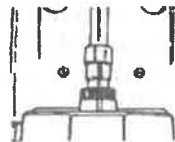

Fig.G-7

VERTICALLY ALIGN THE JIGSAW TO THE POWER STATION'S DRIVE SHAFT HUB

11. Fig.G-9 shows typical vertical misalignment. After you have horizontally aligned the Jigsaw to the drive shaft hub (31), lift the Jigsaw (as in Fig.G-10) until the coupler vertically aligns with the drive shaft hub, shown in Fig.G-11. When they are vertically aligned, tighten the Jigsaw tube setscrews. See Fig.G-12. Recheck the vertical alignment. If it is off, re-do it.

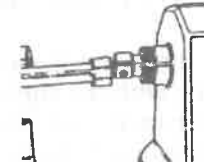

Fig.G-9



It is very important that the two hubs be aligned both horizontally and vertically, so that the coupler does not experience stress caused by misalignment.

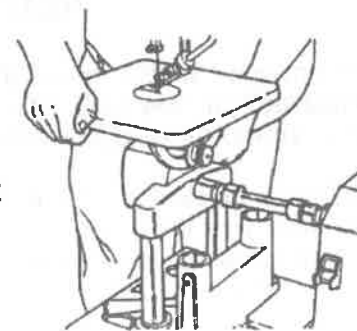

Fig.G-10

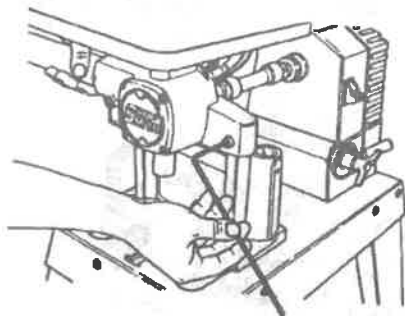

Fig.G-12

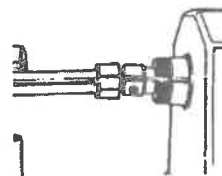

Fig.G-11

PREPARE FOR OPERATIONS

12. Make sure all tube locking setscrews on both the Jigsaw and the Power Station carriage are securely tightened.

13. Unlock the carriage. Then line up the notches on the drive shaft hub with the ridges inside the coupler. With one hand on the carriage and another on the Jigsaw, slide the carriage so that the coupler on the Jigsaw fits over the drive shaft hub (31). See Fig.G-13.

14. After you have securely connected the Jigsaw to the Power Station with the coupler, lock the carriage (21) by turning the handle (19) to the right.

15. Plug in the Power Station and insert the safety key (35). You are now ready to operate the Jigsaw with the Power Station.

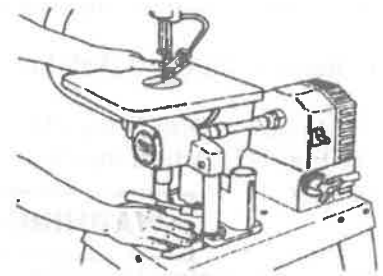

Fig.G-13

POWER STATION SPEED SETTINGS FOR USING THE JIGSAW

The following is a chart of recommended Power Station speed settings to use with the Jigsaw:

OPERATION	HARDWOOD		SOFTWOOD	
	RPM	P.S. SETTING	RPM	P.S. SETTING
Heavy Duty	1150	2-1/2	1150	2-1/2
General Purpose	1050	2	1050	2
Light Duty	950	1-1/2	950	1-1/2
Sabre Saw (all)	1150	2-1/2	1150	2-1/2
Pattern Files (all)	850	1	850	1
Jewelers Blades	850	1	850	1

JIGSAW OPERATIONS-

WARNING

Read and understand the "Safety" and "Operations" sections of your Shopsmith Jigsaw Owners Manual before operating it with the Power Station. Additional information and instructions are provided in the text, Power Tool Woodworking For Everyone. If you have further questions, contact Customer Service as indicated on the back cover of this manual.

DISC SANDER

INSTALLATION

1. Turn the speed dial to its slowest setting. Turn off and unplug the Power Station. Remove the safety key (35) from the switch.
2. Slide the carriage (21) to the left and lock it.
3. Make sure the outer shaft cover (40) is installed over the outer shaft of the Power Station. See Fig.H-1.
4. Remove the drive shaft hub from the drive shaft. See Fig.H-2.
5. Mount the Disc Sander Dust Chute (optional) to the Power Station. See Fig.H-3. Adjust the chute as far open as possible, and lock it in position.

WARNING

If you are going to grind or sharpen metal, do not install the Disc Sander Dust Chute.

6. Mount the Disc Sander. See Fig.H-4.
7. Mount the Extension Table into the carriage's tall tube holes. See Fig.H-5.
8. Unlock the carriage and slide it and the Extension Table to within 1/16" of the Disc Sander. See Fig.H-6.
9. Adjust the height of the Extension Table top to be at the center of the Disc Sander. See Fig.H-7. Tighten the carriage setscrews.
10. Attach your Dust Collector hose if you are sanding wood. See Fig.H-8.
11. Plug in the Power Station and insert the safety key (35). You are now ready to disc sand with the Power Station.

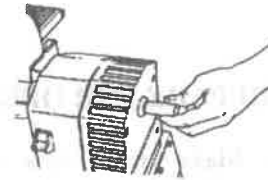

Fig.H-1

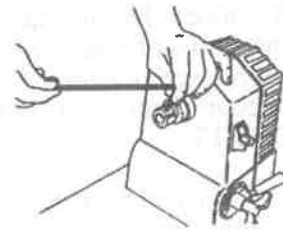

Fig.H-2

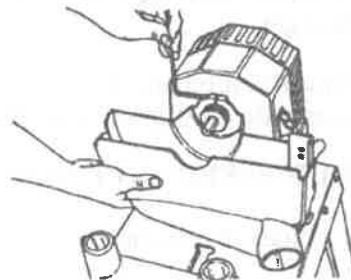

Fig.H-3

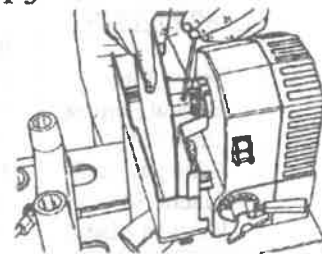

Fig.H-4

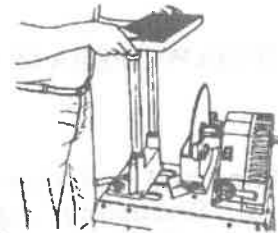

Fig.H-5

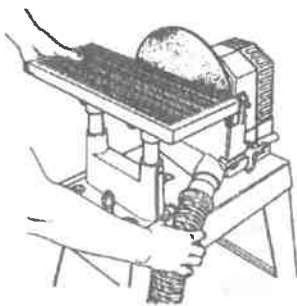

Fig.H-8

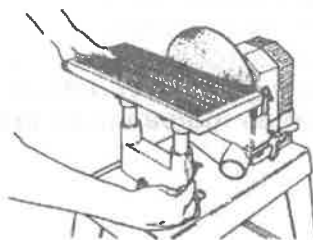

Fig.H-7

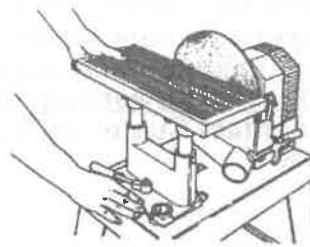

Fig.H-6

WARNING

Do NOT connect dust collection hoses nor operate a dust collection system when sharpening or grinding metal with the Power Station and any accessories.

POWER STATION SPEED SETTINGS FOR USING THE DISC SANDER

The following is a chart of recommended Power Station speed settings to use with the Disc Sander:

GRIT/OPERATION	HARDWOOD		SOFTWOOD	
	RPM	P.S. SETTING	RPM	P.S. SETTING
Coarse	1050	2	1150	2-1/2
Medium	1300	3-1/2	1450	4
Fine	1450	4	1560	4-1/4
GRINDING METAL				
Fine	850	1		

DISC SANDER OPERATIONS--

WARNING

Read and understand your Shopsmith Disc Sander product literature before operating the Disc Sander with the Power Station.

You can also use the Shopsmith Sharpening Guide with the Disc Sander mounted on the Power Station (see Fig.H-9). Consult the Sharpening Guide Owners Manual before operating. Use Speed Settings 1- 2.

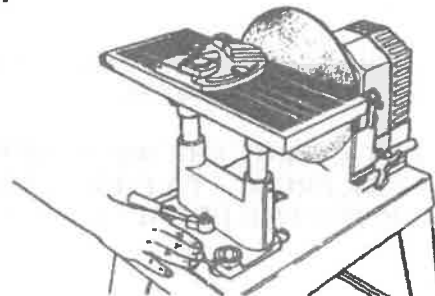

Fig.H-9

DRUM SANDER

MOUNTED ON THE DRIVE SHAFT

1. Turn off and unplug the Power Station, then remove the safety key (35).
2. Remove the drive shaft hub (31) from the drive shaft. See Fig.H-10.
3. Install the Drum Sander on the drive shaft. See Fig.H-11. Use Speed Settings 5- 5-1/2.

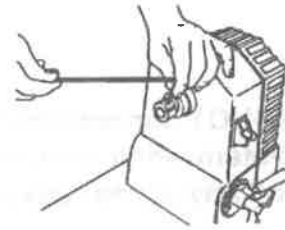

Fig.H-10

WARNING

For operating the Drum Sander, consult the product literature which came with your Drum Sander.

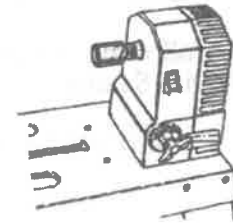

Fig.H-11

MOUNTED ON THE OUTER DRIVE SHAFT

1. Turn off and unplug the Power Station, then remove the safety key (35) from the switch.
2. Remove the outer shaft cover (40) from the outer shaft. See Fig.H-12.
3. Install the Drum Sander on the outer shaft, as shown in Fig.H-13. Use Speed Settings 5- 5-1/2.

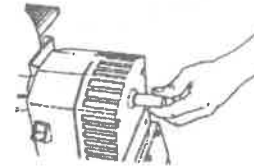

Fig.H-12

DRUM SANDER MOUNTED WITH THE DISC SANDER

1. Turn off and unplug the Power Station, then remove the safety key(35).
2. Install the Drum Sander on the outer shaft, as described above. See Fig.H-13.
3. Install the Disc Sander, as described in the Disc Sander section (the dust chute is optional). See Fig.H-14. Use Speed Settings 2- 4.

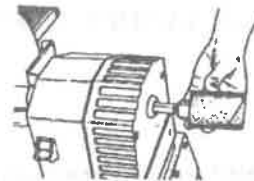

Fig.H-13

FOR OPERATING THE DRUM AND DISC SANDER, CONSULT THE PRODUCT LITERATURE WHICH CAME WITH BOTH THE DRUM SANDER AND THE DISC SANDER.

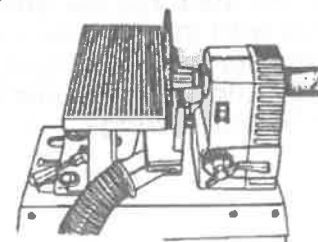

Fig.H-14

WARNING

Never exceed the maximum recommended speed of the slowest accessory when you use two accessories at the same time.

FLUTTER SHEET SANDER

INSTALLED ON OUTER DRIVE SHAFT

1. Turn off and unplug the Power Station, then remove the safety key (35) from the switch.
2. Remove the outer shaft cover (40) from the outer shaft. See Fig.H-15.
3. Install the drill chuck on the outer shaft, as in Fig.H-16. Securely tighten the setscrew.
4. Install the Flutter Sheet Sander in the drill chuck and tighten with the chuck key. See Fig.H-17 and Fig.H-18. Use Speed Settings 5- 5-1/2.

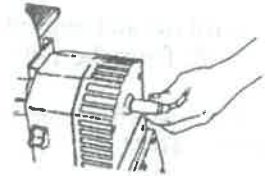

Fig.H-15

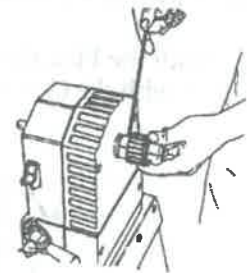

Fig.H-16

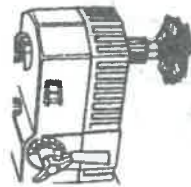

Fig.H-18

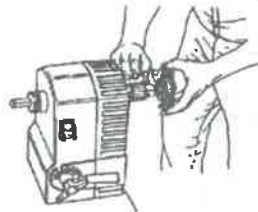

Fig.H-17

INSTALLED ON INNER DRIVE SHAFT

1. Turn off and unplug the Power Station then remove the safety key (35) from the switch.
2. Make sure the outer shaft cover (40) is installed over the outer drive shaft.
3. Remove the drive shaft hub (31) from the inner drive shaft.
4. Install the drill chuck on the drive shaft.
5. Install the Flutter Sheet Sander in the drill chuck and tighten with the chuck key. See Fig.H-19. Use Speed Settings 5- 5-1/2.

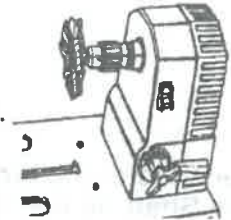

Fig.H-19

FLUTTER SHEET SANDER MOUNTED WITH EITHER THE DISC SANDER OR THE DRUM SANDER (See Fig.H-20.)

1. Turn off and unplug the Power Station, then remove the safety key (35) from the switch.
2. Remove the outer shaft cover (40) from the outer drive shaft.
3. Install the Flutter Sheet, as described above.
4. Install the Disc Sander or the Drum Sander, according to each's instructions on pages 36 and 38 of this manual. Use Speed Settings 2- 4 with the Disc Sander , and 5- 5-1/2 with the Drum Sander.



Fig.H-20

FLEXIBLE SHAFT

1. Turn off and unplug the Power Station, then remove the safety key (35) from the switch.

2. Remove the outer shaft cover (40) from the outer drive shaft. See Fig.H-21.

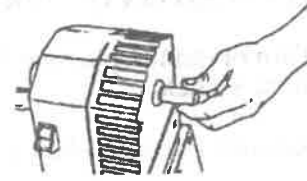

Fig.H-21

3. Install the drill chuck on the outer shaft, shown in Fig.H-22. Securely tighten the setscrew.

4. Install the Flexible Shaft in the drill chuck and tighten with the chuck key. See Fig.H-23.

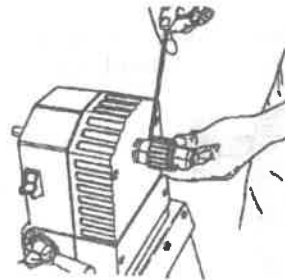

Fig.H-22

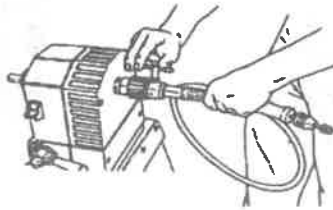

Fig.H-23

CAUTION

Because of the directional of rotation of cutting tools, use the Flexible Shaft on the Outer Drive Shaft **ONLY**.

WARNING

For operating the Flexible Shaft consult the product literature which came with it.

For semi-portable drilling, use Speed Settings 4- 5-3/4.

For power carving with rasps and files, use Speed Settings 8- 9.

For drum sanding , use Speed Settings 5- 5-1/2.

POWER STATION MAINTENANCE SCHEDULE

Every 10 hours- - or monthly	<ul style="list-style-type: none"> • Clean thoroughly. Also wax the carriage holes and the carriage glide surface.
Every 50 hours- - or bi-yearly	<ul style="list-style-type: none"> • Check that the setscrews of upper and lower pulleys are securely tightened..
Lubrication	<ul style="list-style-type: none"> • No additional lubrication is required, because the bearings are permanently lubricated throughout the machine.

POWER STATION TROUBLESHOOTING GUIDE

	PROBLEM	POSSIBLE CAUSE(S)	SOLUTION
Power Plant Problems	•Excessive vibration/noise	•Loose stand, guard or motor mounting hardware	•Check for & tighten all loose hardware
	•Metal to metal scraping noise at low speed	•Variator is rubbing against edge of opening in base	•Setscrew on pulley has loosened, allowing pulley to move variator against opening in stand
	•Accessory running too fast/slow	•Speed change lever out of calibration	•Recalibrate to "1" Speed Setting at slowest speed.
	•Loss of power at high speed	•Worn belts •Insufficient belt tension •Loose hub screws	•Replace both drive belts •Lower motor to increase belt tension •Tighten hub setscrew
	•Loss of power at low speed	•Too much belt tension •Loose hub setscrews	•Raise motor to lessen belt tension •Tighten hub setscrew
	•Won't start	•Wire disconnected at switch •Too much belt tension •Extension cord gauge too small •Blown fuse/circuit breaker •Unplugged from outlet	•Reconnect wires to switch •Raise motor •Use larger gauge wire in extension cord •Replace/reset fuse or circuit breaker •Plug unit into electrical outlet
Carriage Problems	•Carriage difficult to slide	•Too much friction between carriage & top of base	•Clean & wax glide surfaces & base top
	•Carriage moves during operations	•Carriage lock adjustment nut is too loose •Carriage is not locked	•Tighten carriage lock adjustment nut by 1/8 turn •Lock carriage by moving handle to right
	•Major Accessory won't mount in carriage holes	•Setscrew in hole too far •Mounting posts out of alignment •Mounting holes are sticky	•Back out carriage setscrews •Realign Major Accessory •Clean & wax holes in carriage

NOTE

If you have any questions about your Shopsmith Power Station, please call our Customer Service Department TOLL-FREE at 1-800-762-7555, send us an e-mail at techsupport@shopsmith.com, visit our website at www.shopsmith.com, or write to us at: RLFSHOP, LLC. dba Shopsmith, Attn: Customer Service Technical Dept., 6530 Poe Avenue, Dayton, Ohio 45414.

When you contact us, please tell us your Customer Number and Date Code of your equipment. (Your customer number appears on the invoice and mailing labels of the literature we send to you. The date code is located on the serial label sticker on your machine). To keep them handy, please write in the allotted spaces below.

Customer No. _____

Date Code: _____



Shopsmith
6530 Poe Avenue
Dayton, Ohio 45414

845245

Rev A

04/11

©2011 Shopsmith, Inc.
All Rights Reserved
Printed in U.S.A.



Power Station Switch Owner's Manual Supplement

Please make the following change in your Power Station Owner's Manual (845245),
Page 10:

Ref No.	Part No.	Item Description
36	514796	Switch Assy.

The above referenced Part No. has changed and should now read:

36	522278	Switch Assembly
----	--------	-----------------

Note

If you have any further questions or need help, call our Customer Service Department
Toll- Free 800/762-7555.



Shopsmith Inc.
6530 Poe Avenue
Dayton, Ohio 45414

877107

Rev A

01/05

©2005 Shopsmith, Inc.
All Rights Reserved
Printed In U.S.A.



Power Station Switch Owner's Manual Supplement

Please make the following change in your Power Station Owner's Manual (845245),
Page 10:

Ref No.	Part No.	Item Description
36	514796	Switch Assy.

The above referenced Part No. has changed and should now read:

36	522278	Switch Assembly
----	--------	-----------------

Note

If you have any further questions or need help, call our Customer Service Department Toll-
Free 800/762-7555.



Shopsmith Inc.
6530 Poe Avenue
Dayton, Ohio 45414

877107

Rev A

01/05

©2005 Shopsmith, Inc.
All Rights Reserved
Printed In U.S.A.