

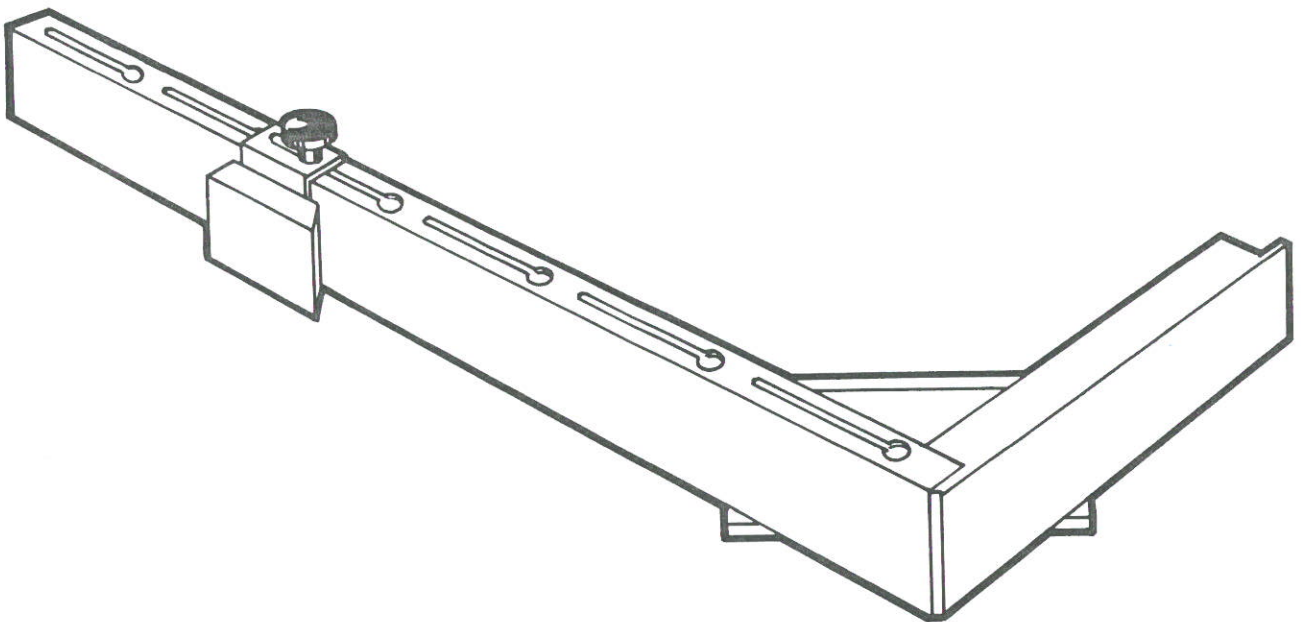

Miter ProTM

Owners Manual

555404



WARNING

Read the SAFETY section and complete the "Alignment" and "Assembly" sections before operating the Miter ProTM.

Table of Contents

Introduction.....	2
Safety Rules.....	2
Exploded View.....	3
Parts List.....	3
Alignment.....	4
Assembly.....	5
Operations.....	7

INTRODUCTION

NOTE

The Miter Pro can be used with the Shopsmith Mark II and Mark VII as well as the Mark V (Models 500 and 510). Though all references and illustrations in this manual are for the Mark V Model 510, they also apply to the Mark II, Mark VII and the Mark V Model 500.

The Shopsmith Miter Pro lets you cut perfect 45 degree miters on your Shopsmith Mark V table saw. Now you can make picture frames, trim moldings and other woodworking projects demanding true 45 degree mitered angles.

You can operate the Miter Pro on either side of the table saw blade. We recommend that right handed people use the Miter Pro on the right side of the saw blade—and we show it this way in this Owners Manual. To operate the Miter Pro in the left miter slot and to the left of the saw blade, just reverse the long and short extensions.

For the cleanest and smoothest cut when operating the Miter Pro with the Mark V, use a hollow-ground, plywood, carbide tipped crosscut or carbide tipped combination blade. You should try out each blade you are considering with a piece of scrap from the stock you intend to use. This way you can judge the optimum feed rate to get the cleanest and smoothest cut. If you don't have a recommended blade and can't achieve a clean, smooth surface, you can cut the stock 1/4" longer than needed at each miter cut and sand each miter to length.

SAFETY RULES FOR THE MITER PRO

- Be sure that you read, understand and follow the Owners Manual of both the Mark V (or that of the Mark II or Mark VII, depending on which one you own) and the Miter Pro. Do NOT try to use the Miter Pro on the Shopsmith Model 10-E or 10-ER.
- Check alignment, assemble, and operate the Miter Pro only as specified in this Owners Manual. Failure to do so could result in injury and equipment damage.
- Use the Miter Pro on Shopsmith products only.
- Always reduce the Mark V to its lowest speed setting before you turn it off.
- Set the circular saw blade to no higher than 1/4" above the top of the workpiece you are cutting.
- When operating the Miter Pro, your standing position should be on the infeed side of the table.
- When operating the Miter Pro, turn on and shut off the Mark V with your left hand after each cut. Never reach over the saw blade.
- Both hands should be securely grasping the Miter Pro and the workpiece during cutting operations.
- Move the headstock so that the saw blade is as far away from the Miter Pro as possible, and as close as possible to the farthest edge of the table insert. This will help eliminate small slivers of wood from dropping down the slot in the table insert.
- The minimum outer length of stock to be cut with the Miter Pro is 6".
- Regularly wax all underside metal of the Miter Pro which contacts the worktable surface. Also regularly wax the worktable. Use furniture wax or "dry lube."
- Install the extension table to the right of the worktable. It will give the Miter Pro and the workpiece extra support if you are using the Miter Pro in the right miter gauge slot.

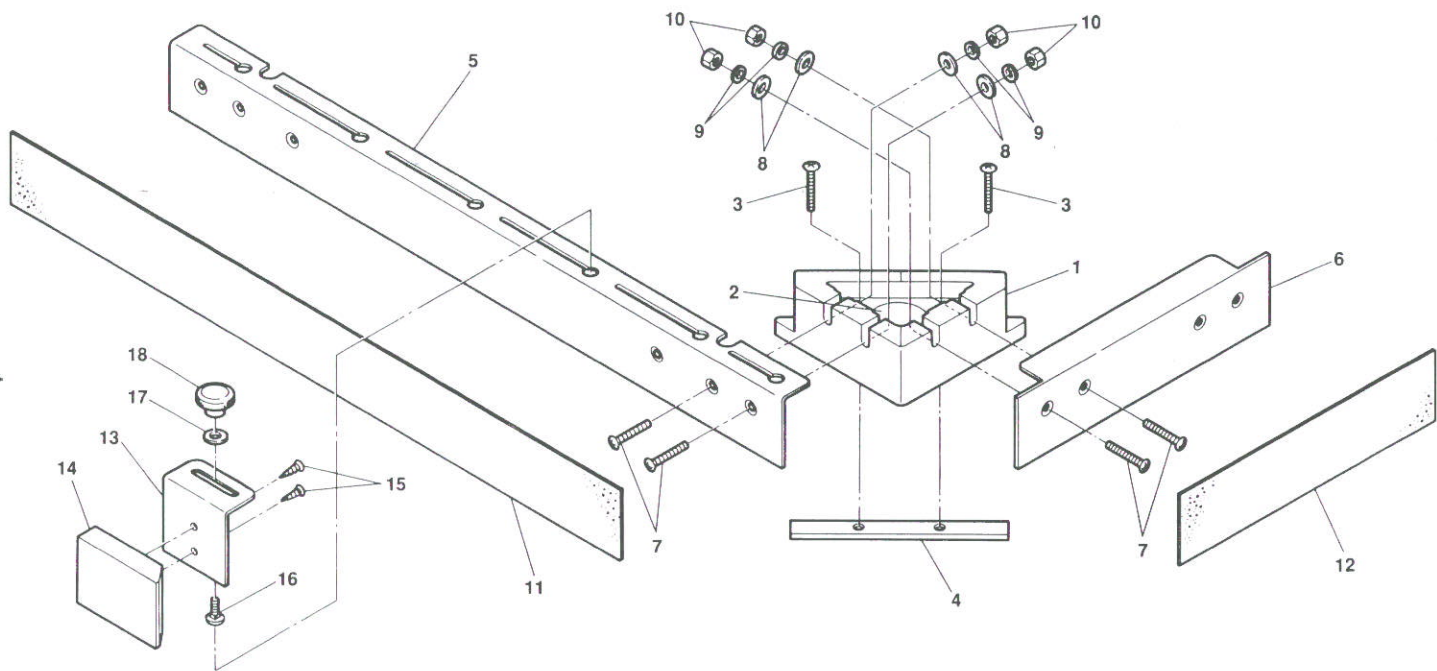

Parts List

Ref. No.	Part No.	Description	Qty.	Ref. No.	Part No.	Description	Qty.
1	515930	Miter Pro Assembly (includes #2)	1	11	515937	Non-slip surface, 24"	1
2	513808	Logo label	1	12	515972	Non-slip surface, 10"	1
3	516128	Phillips screw, panhead 1/4"-20 x 1-1/4"	2	13	515935	Fence stop	1
4	514231	Guide bar	1	14	515936	Stop block	1
5	515933	Long extension	1	15	515706	Wood screw, #8 x 3/4"	2
6	515934	Short extension	1	16	515939	Carriage bolt, #10-24 x 1/2"	1
7	515932	Phillips screw, 1/4"-20 x 1-1/4"	4	17	513864	Special washer, #10	1
8	120392	Flat washer, 1/4" I.D.	4	18	513713	Knob, #10	1
9	120380	Split lock washer, 1/4" I.D.	4	19	515938	Hardware pack (not shown) includes items 9, 10, 11, 12, 17, 18, 19 and 20	1
10	120375	Hex nut, 1/4" x 20	4				

ALIGNMENT

Introduction

Although the Miter Pro is already aligned at the factory, you should re-check it. Before you do this, however, make certain your worktable is aligned with the saw blade. Consult your Mark V Owners Manual for those alignment instructions. Then follow these instructions for checking alignment of the Miter Pro.

Tools Needed:

- Combination square
- Large (#3) Phillips screwdriver

1. Make sure the Mark V is turned off and unplugged.
2. Set up the Mark V in the table saw mode, and set the worktable to expose several inches of the saw blade.
3. Insert the Miter Pro's guide bar (4) in the right miter gauge slot.

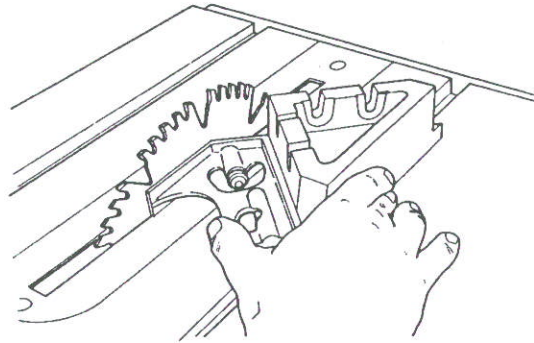

Fig.1

4. Place the 45 degree side of combination square against the saw blade, and hold the 90 degree side against the infeed side of the Miter Pro's casting (1). See Fig.1. Look for any gaps between the blade and the square.
5. "Flip" the square to the outfeed side, as shown in Fig.2, and look for any gaps between the blade and the square.

6. If there is any gap between the blade and the square on either the infeed side or the outfeed side, do the following:

- Use the large Phillips screwdriver to slightly loosen the screws (3) attaching the guide bar to the casting.
- Adjust the casting (1) until there is no more gap between the combination square and either the blade or the casting.
- Tighten the screws (3).

NOTE

This procedure assumes you have accurately aligned the worktable and the blade according to your Mark V Owners Manual. If you cannot eliminate a gap as described above for the infeed and outfeed side, you need to "split the difference" of the gap. Do this by loosening the two screws (3) and adjusting the casting so the gap between the square and the blade on the infeed side matches the gap between the square and the blade on the outfeed side. When the gaps match, tighten the screws.

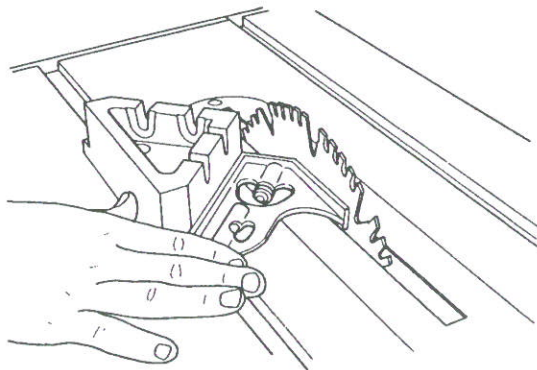

Fig.2

ASSEMBLY

Introduction

As mentioned earlier, you can use the Miter Pro in either miter gauge slot in the Mark V worktable. Though the instructions below and the "Operations" section show the Miter Pro being used in the right slot, all instructions in this manual apply to using the Miter Pro in the left slot as well. If you wish to use the Miter Pro in the left slot, you just need to keep in mind the "mirror image" of these instructions and illustrations.

Tools Needed:

- 7/16" open end wrench
- Medium Phillips screw driver
- Large (#3) Phillips screw driver
- Square
- Dry lube, silicon spray or paste wax

NOTE

Before you assemble the Miter Pro, complete the preceding "Alignment" section, including accurately aligning the Mark V.

PREPARE THE MARK V

1. Make sure the Mark V is turned off and unplugged.
2. Install the worktable on the Mark V and place it in the horizontal position (if not done already). Do not expose the saw blade through the table insert.

ASSEMBLE THE MITER PRO

3. Place the guide bar (4) in the left slot with the casting pointing toward the left, shown in Fig.3.
4. Install the short extension (6) by fitting two screws (7), flat washers (8), lock washers (9) and nuts (10) in the extension, as in Fig.4. Then lower the screws into the two slots in the near side of the casting, as shown in Fig.5. The washers (8 and 9) must be on the side of the nuts (10). Finger tighten.

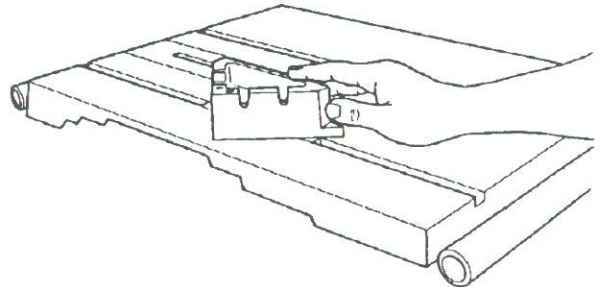

Fig.3

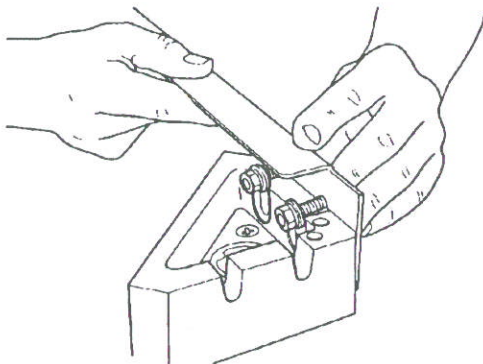

Fig.5

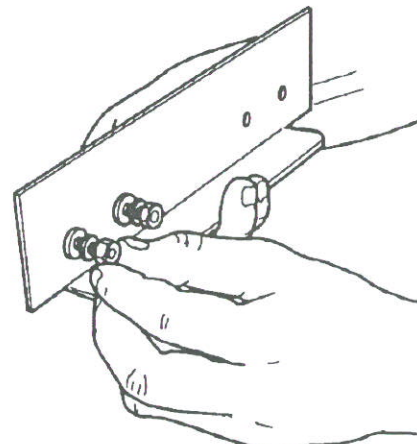

Fig.4

5. Install the long extension (5) by fitting two screws (7), flat washers (8), lock washers (9) and nuts (10) in the extension, as in Fig.6, then lower the screws into the two slots in the far side of the casting (1). The washers (8 and 9) go on the side of the nuts (10). Finger tighten. The top edge of each extension should be pointed toward the casting. Make sure that the bottom edges of both extensions are flat on the table surface.

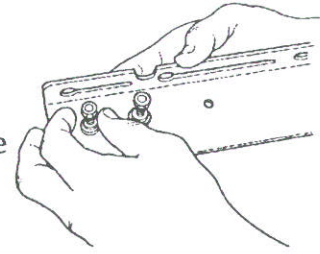

Fig.6

6. Using the large Phillips screw driver and 7/16" open end wrench, securely tighten the screws and nuts on both extensions. See Fig.7.

INSTALL THE NON-SLIP SURFACES

7. Leave the assembled Miter Pro on the worktable as before. Peel the backing from the short non-slip surface (12), as in Fig.8.

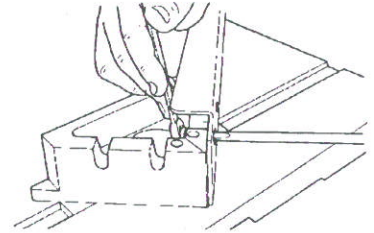

Fig.7

8. Hold it close to where it will cover the entire surface of the short extension, as in Fig.9. Keep 1/16" clearance between the bottom of the non-slip surface and the bottom of the extension. When in position, press the non-slip surface to the short extension. See Fig.10.

9. To install the long non-slip surface (11) on the long extension, repeat Steps 7 and 8, using the long non-slip surface.

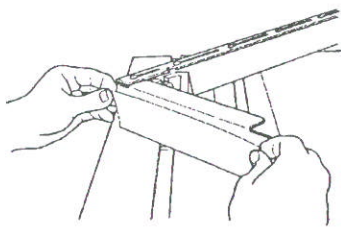

Fig.10

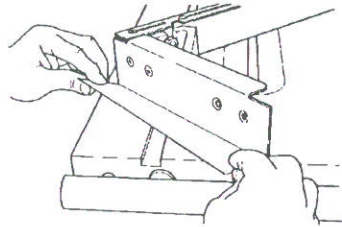

Fig.9

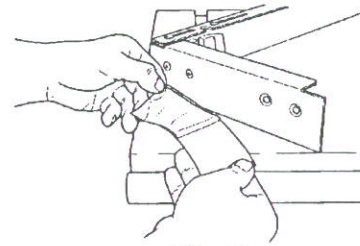

Fig.8

ASSEMBLE THE STOP BLOCK

10. See Fig.11 and note the position of the stop block (14) to the fence stop (13). Using two screws (15), attach the stop block (14) to the fence stop (13). This will face the angled tip of the stop block away from the non-slip surface on the long extension, as in Fig.11.

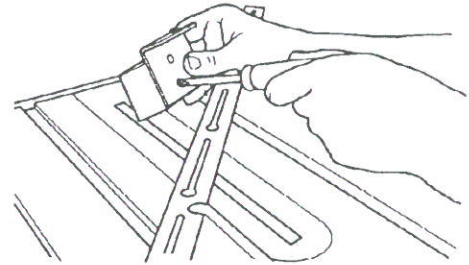

Fig.11

11. Install the knob (18), washer (17) and carriage bolt (16) in the fence stop, shown in Fig.12. Do not tighten the knob.

12. Insert the head of the carriage bolt through the wide opening in any slot on the long extension. Slide the stop block to the right and finger tighten the knob. The angled tip of the stop block should be pointed toward the intersecting extensions, as in Fig.13.

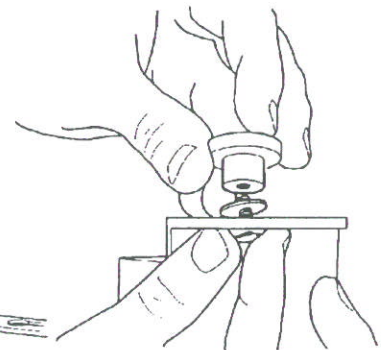

Fig.12

You are now ready to operate the Miter Pro with the Mark V. Read the "Operations" section before using it.

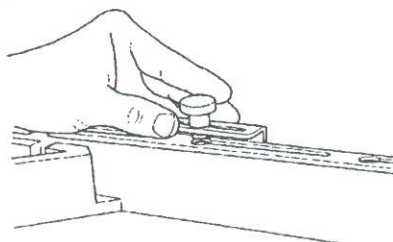

Fig.13

OPERATIONS

Introduction

This section will take you step-by-step through the process of making a picture frame. These techniques will be virtually the same for other projects as well.

These guidelines will ALWAYS stay the same:

1. Exert mild pressure on the Miter Pro toward the saw blade as you make a cut. After a cut is completed, exert mild pressure on the Miter Pro away from the saw blade. This will help assure accuracy from cut to cut, and will insure that a small space exists between the just-cut stock and the blade after the cut is made. This space allows for safer operation and prevents burning or chipping out of your stock.
2. Make all shaping and rabbet cuts in long pieces of the stock. Next, cut the stock to rough lengths, if necessary for ease of operation. Then follow the instructions for operating the Miter Pro.
3. You make the first miter cut with the outer edge of the workpiece held against the short extension. The complementary **second** cut is made with the outer edge of the workpiece held against the long extension. Do this and every corner of the picture frame will always consist of two complementary miter cuts— and a true 90 degree joint.
4. Hold the workpiece against the Miter Pro with the rabbet facing down toward the table and the outer edge of the workpiece against an extension.
5. The sequence of sides to cut is— top, bottom, left, right.
6. Make your first cut on the scrap end of the workpiece.

Follow the above guidelines as well as the instructions below, and you should get great picture frames every time.

A nice feature of the Miter Pro is the ability to pencil lines on the top of the long extension where you have tightened the stop block. With the top/bottom and left/right lengths marked, you can duplicate your original picture frame without needing to measure again. This assumes the rabbet is identical to the first rabbet and the stock width is the same.

NOTE

Mount an extension table for extra support of the long extension and workpiece. See Fig.14.

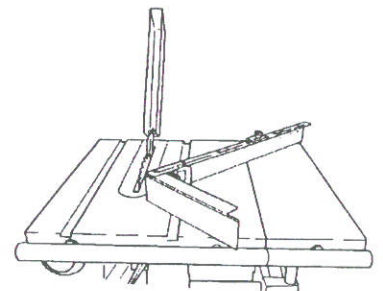

Fig.14

PREPARE THE FRAME STOCK

1. While the stock is full length, perform shaping or routing on the frame's top surface as you desire.
2. Cut a rabbet 1/4" wide x 1/4" deep (see following NOTE) in the unexposed, back inner surface. This rabbet will ring the inside of your finished picture frame and hold the picture in the frame.

NOTE

The depth of the rabbet depends on the thickness of your picture backing, canvas stretcher or mounting frame. (If you use glass in the frame, its thickness must also be added in figuring the total rabbet depth.) For instance, if your picture frame is for an oil painting which is on a stretcher 3/4" deep, make the depth of the rabbet 3/4" plus 1/8" (for fastening it with brads), for a total rabbet depth of 7/8." Make sure your stock is thick enough to handle the depth of rabbet you need.

3. Cut the stock to workable lengths if necessary, as they are easier to handle. A workable length is usually the top and bottom pieces together, and the left and right sides together. Use the formulas below to compute each workable length of stock:

For the top and bottom pieces together, double the number you derive below—

[Picture width - (2 x rabbet width)] + [(2 x stock width) + 1/2" of scrap].

For left and right side pieces together, double the number you derive below—

[Picture length - (2 x rabbet width)] + [(2 x stock width) + 1/2" of scrap].

Example:

You want to frame an 8" x 10" photo, using 2" wide molding with a 1/4" rabbet. Since the molding comes in 8' lengths, you would like to cut it to more manageable lengths. The first length (comprised of the top and bottom pieces) are figured as such:

$$\begin{aligned} & [8" - 2(1/4")] + [2(2") + 1/2"] \\ & \quad \downarrow \qquad \qquad \downarrow \\ & 7-1/2" \quad + \quad 4-1/2" \qquad = 12" \text{ for each piece} \\ & 12" \times 2 \text{ sides} \qquad = 24" \end{aligned}$$

So the first length of molding to cut for ease of handling is 24."

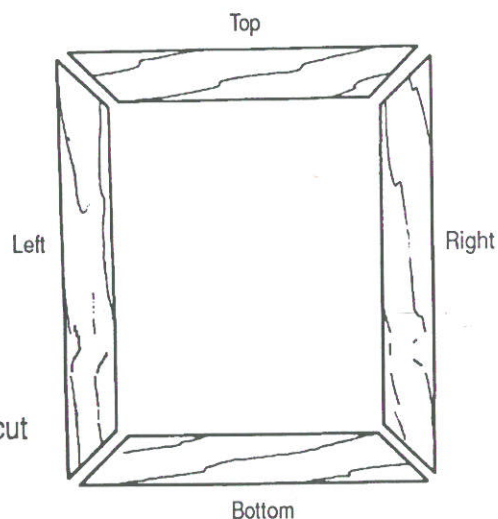

Fig.15

The second length (comprised of the left and right pieces) of molding to cut for ease of handling is figured as such:

$$\begin{aligned} & [10" - (2 \times 1/4")] + [2 \times 2" + 1/2"] \\ & \quad \downarrow \qquad \qquad \downarrow \\ & 9-1/2" \quad + \quad 4-1/2" \qquad = 14" \text{ for each piece} \\ & 14" \times 2 \text{ sides} \qquad = 28" \end{aligned}$$

So the second length of molding to cut for ease of handling is 28" .

PREPARE THE MARK V

1. Make sure the Mark V is unplugged, shut off and set to "Slow."
2. Set up the Mark V in the table saw mode. Use a smooth cutting saw blade, as recommended in the front of this manual.

WARNING

Be sure the blade is clean and sharp. A dull blade or a blade coated with wood pitch may cause a kickback and injury.

CAUTION

Move the headstock so that the saw blade is as far away from the Miter Pro as possible. This reduces the space between the blade and the insert slot, which will help stop small slivers of wood from dropping down the slot in the table insert. See Fig.16.

3. With a straightedge, pencil a line from the saw blade's inside teeth onto the front of the table. See Fig.17. This line will make the cut line on the workpiece easier to line up with the saw blade.

4. Plug in the Mark V.

SAW THE TOP PIECE

5. Hold the outer edge of stock you had previously rough cut against the short extension. Line it up so the saw blade will cut at the corner of the stock. Make sure the rabbet faces away from the short extension and down. See Fig.18.

6. Turn on the Mark V, turn it up to speed and make the cut. Turn the speed dial to "Slow" and shut off the Mark V. When completely stopped, remove the scrap.

7. Turn the stock rabbet-side up and facing toward you. Measure from the back vertical edge of the rabbet along the miter cut. See Fig.19. The length you will measure will be the actual width of the picture.

8. Use a square to transfer the cut line to the other side (the top, exposed side) of the stock.

9. Turn the stock rabbet-side down and with the rabbet facing away from the long extension. Place the outer edge of the stock against the long extension.

10. Line up the cut line on the workpiece with the blade's cutting line, then secure the stop block at the end of the stock. See Fig.20.

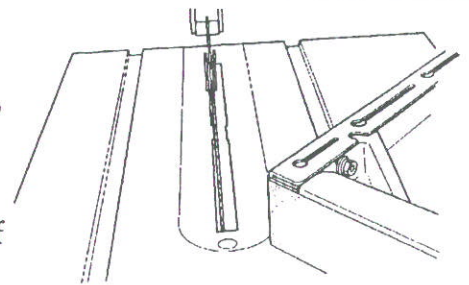

Fig.16

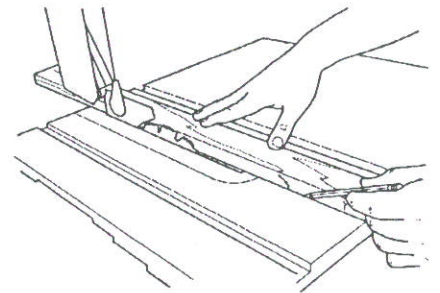

Fig.17

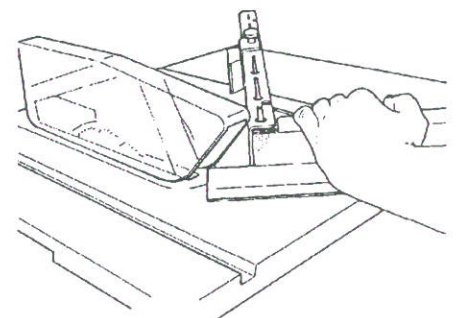

Fig.18

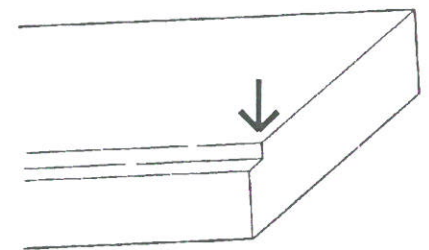

Fig.19

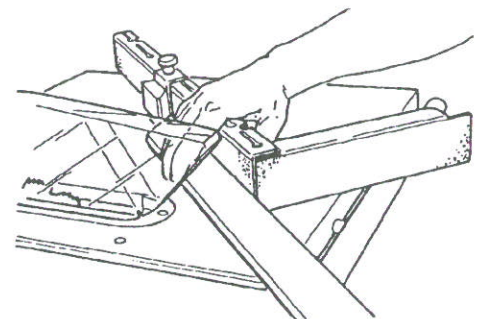

Fig.20

NOTE

The 45 degree angle on the stop block complements the stock's miter. This wedges the stock and gives it extra support. Also, remember to put mild pressure on the Miter Pro toward the saw blade when making the cut.

11. Turn on the Mark V and turn the speed dial up to sawing speed.
12. Saw the stock, then turn the speed dial to "Slow" and shut off the Mark V.
13. Remove the stock from the Miter Pro and lightly label the back of the piece "top."

SAW THE BOTTOM PIECE

14. Hold the outer edge of the stock remaining from the previous cut against the short extension, with the rabbet facing down and away from the short extension.
15. Turn on the Mark V and turn it up to sawing speed.
16. Saw a 45 degree miter, then turn the speed dial to "Slow" and shut off the Mark V.
17. Pivot the stock around to the long extension with the rabbet down and away from the long extension. Fit it against the stop block (refer to NOTE above).
18. Turn on the Mark V and turn it up to sawing speed.
19. Saw the second 45 degree miter, then turn the speed dial to "Slow" and shut off the Mark V. Lightly label the back of the piece "bottom."

WARNING

After the cut is made, turn the Mark V to "Slow" and turn off the machine. Return the Miter Pro and the just-cut piece to their starting position. The 45 degree angle and the stop block do not permit you to remove the workpiece from the Miter Pro after you have made the cut. Be careful to hold the stock firmly against the extension during both the forward cutting motion and the backward motion. Never pull the cut piece back past a moving blade.

SAW THE LEFT PIECE.

20. Repeat Steps 5 through 13, except use the longer rough-cut stock and the picture's length measurements. Lightly label the back of the piece "left."

SAW THE RIGHT PIECE

21. Repeat Steps 14 through 18. Lightly label the back of the piece "right."

WARNING

After the cut is made, turn the Mark V to "Slow" and turn off the machine. Return the Miter Pro and the just-cut piece to their starting position. The 45 degree angle and the stop block do not permit you to remove the workpiece from the Miter Pro after you have made the cut. Be careful to hold the stock firmly against the extension fence during both the forward cutting motion and the backward motion. Never pull the cut piece back past a moving blade.

You now have all four sides of your picture frame cut. Dry fit the pieces. Use carpenters glue and whichever method you choose to permanently assemble your picture frame. Make sure that you do not allow any glue to touch the exposed face of the frame, since the glue could cause the wood to not absorb stain and finish.

There are several methods of permanently joining the mitered sides. Choose one that fits the type, size and shape of the wood you used. For further suggestions, consult the Shopsmith publication, **Power Tool Woodworking for Everyone**, or other books on picture frame making.

If you are using the Miter Pro to cut ceiling molding, floor molding or other pieces which must remain long and uncut, consider mounting a floating extension table to your Mark V, shown in Fig.21. Also use a "C"-clamp to fasten a straight board to the long extension.

Fig.22 shows a scrap stop block clamped to the extension. Notice in Fig.22 that the complementary cut being made looks like Fig.20. It does because it IS alike-- except for Fig.22's extension-- since larger, longer projects follow the same instructions as the smaller picture frames.

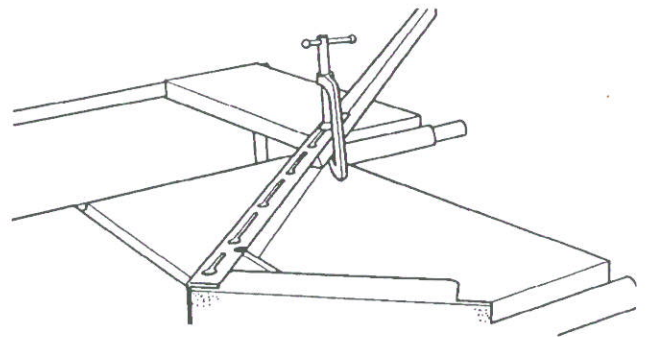

Fig.21

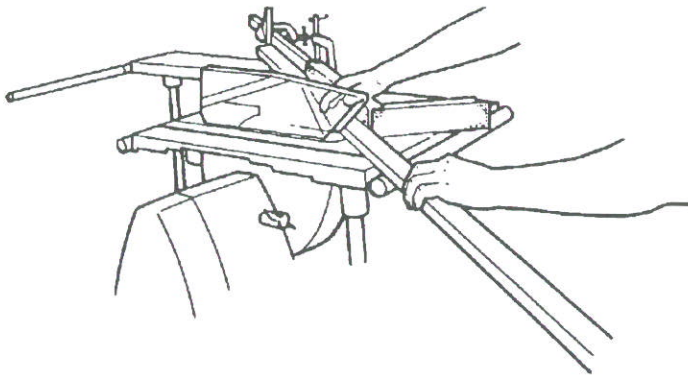

Fig.22



Serving Your Needs

Your Shopsmith equipment is covered by the **Shopsmith Gold Medal Buyer Protection Plan**. This plan includes a 30-day money-back guarantee, a full one-year warranty, and a lifetime reconditioning program.

30-Day Money-Back Guarantee

We guarantee your complete satisfaction! You can try the equipment for 30 days at no risk before you decide whether to keep it or not. Use it to make as many projects as you like. Compare it, feature for feature, with other equipment. Then, if the equipment isn't everything we say, call Customer Services and we'll advise you how to return it for a prompt and complete refund. We'll even pay for shipping.

Full One-Year Warranty

Your equipment is guaranteed against all defects in parts and workmanship for ONE FULL YEAR from the date of receipt. Here are the details:

Shopsmith warrants to the owner of Shopsmith woodworking equipment that the equipment will be free of manufacturing defects in materials and workmanship for a period of one year from the date of receipt. All claims must be submitted in writing within one month after expiration of the one-year warranty period. Shopsmith shall, by repair of, or at its option replacement, remedy any defect or malfunction covered by this warranty. This warranty excludes and does not cover defects, malfunctions, or failures of your Shopsmith equipment which are caused by damage while in your possession or that of a previous owner or by unreasonable use, including your failure or the failure of any previous owner to provide reasonable and necessary maintenance.

Personal injury or property damage may result if equipment is interchanged with non-Shopsmith brand equipment. Therefore, Shopsmith, Inc. disclaims all liability and excludes all warranties of merchantability and fitness for a particular purpose if this equipment is used with a non-Shopsmith brand unit.

THIS WARRANTY IS IN LIEU OF ALL OTHER EXPRESS WARRANTIES. IN NO EVENT SHALL SHOPSMTIH BE LIABLE FOR ANY CONSEQUENTIAL OR INCIDENTAL DAMAGES. Some states do not allow the exclusion or limitation of consequential or incidental damages, so the above limitation may not apply to you. This warranty gives you specific legal rights, and you may also have other rights which vary from state to state.

Lifetime Reconditioning Program

Our equipment is designed for years of constant, rugged, uninterrupted operation. However, to insure the continued usefulness of your unit, we offer a unique Lifetime Reconditioning Program.

At any time, regardless of the age of your equipment, you can send it to us (round trip shipping at owner's expense), and we'll rebuild it and touch up the paint. We'll replace wearing parts such as bearings, seals, and belts. Your reconditioned equipment will come back to you with a new 90-day full warranty. Reconditioning or repair will be done for a cost that will not exceed one-third of the current list price of the equipment at the time of repair. If parts other than normal wearing parts need replacement, an estimate will be submitted to the owner for approval.

Warranted Service

To repair or replace a part in the equipment while it's still under warranty, call Customer Services.

Depending on the part you need or the type of repair, you may be able to replace or repair it yourself. If you are unable to do the repair yourself, Customer Services will instruct you where to send the part or your equipment. If the warranty is applicable, the part will be repaired at no charge.

Out-of-Warranty Service

If your equipment is out of warranty and needs service, call Customer Services for instructions on how you can have the part repaired at our Factory or Store for a fee. Customer Services will help you diagnose the problem, give you an estimate of the cost, and instruct you where to send the part or equipment for repair.

Shopsmith Stores carry a limited number of replacement parts and can perform some repairs. Call ahead to see if they can provide the part or the service you need.

How to Order Parts

To order replacement parts, first consult the **Parts List**. Then write or call for current price information.

How to Return Parts

Should you need to return the equipment, call Customer Services for packing and shipping information.

Customer Services

Where to Write—Send inquiries to:
Shopsmith, Inc.
Customer Services
3931 Image Drive
Dayton, Ohio 45414

Where to Phone—Shopsmith maintains toll-free telephone numbers during normal business hours.

For service call:
1-800-762-7555 (Continental U.S., Hawaii, Alaska, Puerto Rico and U.S. Virgin Islands)
1-800-268-3998 (Canada)
1-513-898-6070 (Dayton, OH area)

To place an order call:
1-800-543-7586 (Continental U.S., Hawaii, Alaska, Puerto Rico and U.S. Virgin Islands)
1-800-268-3998 (Canada)
1-513-898-6070 (Dayton, OH area)

When you write or call, tell us your **Customer Number** and the **Date Code** of your equipment. (Your customer number appears on the invoice and the mailing labels of the literature we send you. The date code is stamped on the equipment.) Please write the numbers in the space provided here.

Customer No. _____

Date Code _____

Shopsmith Inc.

3931 Image Drive
Dayton, Ohio 45414-2591

©1990 Shopsmith, Inc. All rights reserved.
Shopsmith® and Miter Pro® are registered trademarks of Shopsmith, Inc.

PL-5246 1/90